

RUSSELL CITY COUNCIL MEETING
City Hall - 133 W. 8th St. - Russell, Kansas
Date: Tuesday, September 15, 2020 Time: 4:30 p.m.

To allow for proper social distancing to limit the spread of COVID-19, a limited number of people may attend the meeting in person. If you cannot attend in person or choose not to, you can watch the live-streamed event at <http://www.russellcity.org/274/GoTo-Meeting>.

CALL TO ORDER

INVOCATION/PLEDGE OF ALLEGIANCE

APPROVAL OF AGENDA

PUBLIC COMMENTS

Members of the public are welcome to use this time to make comments about City matters. (A maximum of five minutes) Public Comments may be presented in person or can be submitted in writing and emailed to kayla@russellcity.org. Please include your full name and address when submitting your written comment.

PRESENTATIONS AND PUBLIC HEARINGS

- 1) Water Conservation Status

CONSENT AGENDA

- 1) Approval of September 1, 2020, Council Meeting minutes
- 2) Appropriation Ordinance No. A-09-20
- 3) Licenses:
 - a. Building
Elite Building & Renovations, LLC, 4409 Vista Dr., Hays, KS
 - b. Doors/Windows/Guttering/Siding
Mike's Handyman.438 W 2nd St, Russell, KS
 - c. Electrical
Meier Electric Inc., 419 W. 24th St., Hays, KS
 - d. General
Keen Project Solutions, LLC, 3001 SE Convenience Blvd, Ste 101, Ankeny, IA

UNFINISHED BUSINESS

- 1) Unit #10 Base Alignment Project
- 2) CDBG St. John Waterline Project Drawdown #3

NEW BUSINESS

- 1) Resolution Authorizing the Removal of General Nuisances at 1337 N. Elm Street
- 2) Special Event Application and Temporary CMB License - Bricks, Broncs, and BBQ
- 3) Review and Consideration of Bids for Sanitation Truck Replacement
- 4) Advanced Metering Infrastructure

DEPARTMENT REPORTS

PUBLIC COMMENTS

Members of the public are welcome to use this time to make comments about City matters. (A maximum of five minutes) Public Comments may be presented in person or can be submitted in writing and emailed to kayla@russellcity.org. Please include your full name and address when submitting your written comment.

EXECUTIVE SESSION

- 1) Preliminary Discussion of the Acquisition of Real Property
- 2) Consultation with an Attorney on Matters Deemed Privileged in an Attorney-Client Relationship

GOVERNING BODY/CITY MANAGER COMMENTS**ADJOURNMENT**

In compliance with the Americans with Disabilities Act, the City of Russell will provide reasonable accommodations for all public meetings. Persons requiring accommodations in attending any of our public meetings should contact Katrina Woelk, City Clerk/ Finance Director, at 785.483.6311 a minimum of 48 hours before the meeting.

This page intentionally left blank.



September 1, 2020

**Russell City Council Meeting – Minutes
City Hall
Russell, KS**

Mayor Mader called the City Council meeting to order at 4:30 PM with the following members in attendance: Councilmembers Madden, Cross, Wagner, Matt Driscoll, Talbott, Stoppel, Mitch Driscoll and Morrill.

The following staff members participated by virtual conference: City Clerk Katrina Woelk, Public Works Director Rich Krause, and Fire Chief Dylan Riedel. The Following staff members were present: City Manager Jon Quinday, Assistant City Manager Kayla Schneider, Building Official Roger Sells, Electric Director Duane Banks and Police Chief Dale Weimaster.

Approval of Agenda

Councilmember Cross made a motion to approve the agenda with the removal of Executive Sessions 1. Preliminary Discussion of the acquisition of real property and 2. Consultation with an attorney on matters deemed privileged in an attorney-client relationship. Councilmember Stoppel seconded. The motion carried unanimously.

Public Comments

None

Presentations and Public Hearings

1. Water Conservation Status

City Manager Quinday updated the council on the status of the City's wells and Big Creek.

2. Public Hearing – Dangerous Structure at 1537 N Lincoln St

Building Official Roger Sells gave an overview of the condition of the structure at 1537 N Lincoln St. Aubrey Higgins, mother of the owner, stated that her son tried to sell the property, but after the notice the buyer was no longer interested.

Consent Agenda

Councilmember Cross made a motion to approve the consent agenda. Councilmember Madden seconded. The motion carried unanimously.

Unfinished Business

1. Resolution Ordering the Repair or Removal of Dangerous Structure at 1537 N Lincoln

Councilmember Cross made a motion to approve the Resolution finding the structure(s) house and accessory buildings at 1537 N Lincoln unsafe and direct the structure to be repaired or removed and the premises made safe and secure. Councilmember Wagner seconded. The motion carried unanimously.

2. Resolution Authorizing Removal of General Nuisances at 1443 N Lincoln

Councilmember Cross made a motion to approve the Resolution Authorizing the removal of the nuisance(s) from 1443 N Lincoln and providing the abatement costs, if any, incurred by the city shall be charged against the lots or parcels of ground on which the nuisance is located. Councilmember Wagner seconded. The motion carried unanimously.

3. CDBG St. John Waterline Project Drawdown #2

Councilmember Stoppel made a motion to approve the CDBG St. John water line project Draw Down #2 in the amount of \$95,700.00. Councilmember Talbott seconded. The motion carried unanimously.

New Business

1. Ordinance Amending Contractor's Continuing Education Requirements

No action was taken

2. SPARK Funded COVID-19 Mitigation Access Alterations

Councilmember Cross made a motion to approve bid from Stoppel Construction, contingent upon receipt of direct aid SPARK grant funds for the project. Councilmember Matt Driscoll seconded. Motion carried 7-0 with Councilmember Stoppel abstaining.

3. SPARK Funded Telework Capacity Improvements

Councilmember Cross made a motion to approve proposal from Gilmore Solutions, contingent upon receipt of direct aid SPARK grant funds for the project. Councilmember Stoppel seconded. Motion carried unanimously.

4. Unit #10 Base Alignment Project

No action was taken

Department Reports

Assistant City Manager Kayla Schneider provided a report on the 2020 swimming pool operations

Public Comments

None

Executive Session

None

Adjournment

Councilmember Cross made a motion to adjourn the meeting. Councilmember Matt Driscoll seconded the motion. The motion carried unanimously.

Katrina Woelk, City Clerk

CITY OF RUSSELL
 ACCOUNTS PAYABLE
 APPROPRIATION ORD. A-09-20
 08/19/20 THRU 09/15/20

| FUND NO# | FUND NAME | AMOUNT |
|----------|------------------------------------|----------------|
| 10 | GENERAL FUND | \$84,456.95 |
| 12 | AIRPORT FUND | \$259.38 |
| 16 | INDUSTRIAL FUND | \$200.00 |
| 18 | BOND & INTEREST FUND | |
| 22 | LIBRARY FUND | |
| 24 | FIRE EQUIPMENT FUND | |
| 26 | RECREATION FUND | |
| 28 | PERSONNEL BENEFITS | \$50,472.22 |
| 29 | SPECIAL HIGHWAY FUND | \$36,938.25 |
| 36 | ELECTRIC FUND | \$588,724.47 |
| 37 | WATER IMPROVEMENT FUND | \$447,269.54 |
| 38 | WATER FUND | \$58,527.62 |
| 39 | SANITATION/RECYCLING FUND | \$11,498.73 |
| 40 | ELECTRIC DEPRECIATION FUND | \$11,445.00 |
| 45 | WASTEWATER REPLACEMENT FUND | \$2,225.00 |
| 46 | WASTEWATER FUND | \$4,598.34 |
| 47 | SPECIAL PARK & RECREATION | |
| 48 | SANITATION RESERVE | |
| 51 | CAPITAL IMPROVEMENTS FUND | |
| 52 | EQUIPMENT RESERVE FUND | \$992.19 |
| 61 | MUNICIPAL COURT FUND | \$977.89 |
| 65 | INDUSTRIAL DEV/ECON DEV GRANT FUND | |
| 66 | DEINES CENTER GRANT | |
| 68 | WATER CAPITAL PROJ FUND | |
| 70 | AIRPORT PROJECT FUNDS | \$20.45 |
| 71 | PFIEFER WELL EXPANSION | |
| 80 | HEALTH INSURANCE TRUST | |
| 81 | GOLF COURSE IMPROVEMENT FUND | |
| 82 | SINK OR SWIM | |
| 83 | INSURANCE PROCEEDS FUND | |
| 84 | RISK MANAGEMENT RESERVE | \$3,124.89 |
| 85 | DRUG FORFEITURE FUND | |
| 86 | JOHNSON TRUST FUND | |
| 87 | FIREFIGHTER ACTIVITY | \$478.73 |
| 89 | DEINES CENTER TRUST FUND | |
| 90 | DONATION FUND | |
| 99 | TRANSFER TO UMB TO COVER P/R | |
| | ** TOTALS ** | \$1,302,209.65 |

9/09/2020 3:34 PM
 VENDOR SET: 01 City of Russell
 BANK: A/R/R POOL CASH ACCOUNT
 DATE RANGE: 8/19/2020 THRU 9/15/2020

A/P HISTORY CHECK REPORT

PAGE: 2

| VENDOR I.D. | NAME | STATUS | CHECK DATE | INVOICE AMOUNT | DISCOUNT | CHECK NO | CHECK STATUS | CHECK AMOUNT | VENDOR I.D. | NAME | STATUS | CHECK DATE | INVOICE AMOUNT | DISCOUNT | CHECK NO | CHECK STATUS | CHECK AMOUNT |
|-------------|---------------------------------|--------|------------|----------------|----------|----------|--------------|--------------|-------------|---------------------------------|--------|------------|----------------|----------|----------|--------------|--------------|
| 13173 | MIDWEST ENERGY, INC. | D | 8/24/2020 | 1,592.10 | | 000418 | | 1,592.10 | 14144 | NORTHWEST KS PLANNING/DEV | R | 9/01/2020 | 047429 | | 047429 | | 5,000.00 |
| 11130 | KANSAS GAS SERVICE | D | 8/26/2020 | 3,653.84 | | 000486 | | 3,653.84 | | PORTER, TRAVIS A | R | 9/15/2020 | 047449 | | 047449 | | 230.00 |
| 11101 | KS DEPARTMENT OF REVENUE | D | 8/25/2020 | 21,005.56 | | 000487 | | 21,005.56 | 01067 | AIRGAS, INC | R | 9/15/2020 | 047450 | | 047450 | | 1,510.61 |
| 14069 | NEW-TECH, LLC | D | 8/20/2020 | 52.95 | | 000497 | | 52.95 | 01080 | ALL S AUTO GLASS | R | 9/15/2020 | 047451 | | 047451 | | 2,516.60 |
| 11114 | KMEA - EHP 2 OPERATING ACCT | D | 9/04/2020 | 46,989.58 | | 000498 | | 46,989.58 | 01100 | ALITEC, INC. | R | 9/15/2020 | 047452 | | 047452 | | 83.76 |
| 11114 | KMEA - EHP 2 OPERATING ACCT | D | 9/03/2020 | 61,543.25 | | 000499 | | 61,543.25 | 01154 | AMERICAN TEST CENTER, INC | R | 9/15/2020 | 047453 | | 047453 | | 1,421.00 |
| 11114 | KMEA - EHP 2 OPERATING ACCT | D | 8/20/2020 | 287,448.01 | | 000500 | | 287,448.01 | 01966 | A/R/C-KANSAS, INC., SHEARS DIVI | R | 9/15/2020 | 047454 | | 047454 | | 149,912.55 |
| 11114 | KMEA - EHP 2 OPERATING ACCT | D | 9/14/2020 | 3,028.19 | | 000501 | | 3,028.19 | 01202 | ABRAMARK UNIFORM & CAREER APPAR | R | 9/15/2020 | 047455 | | 047455 | | 879.61 |
| 11114 | KMEA - EHP 2 OPERATING ACCT | D | 8/26/2020 | 70,044.23 | | 000502 | | 70,044.23 | 01230 | MICHAEL DALE SCHNOSCH | R | 9/15/2020 | 047456 | | 047456 | | 2,639.89 |
| 13134 | MUNICIPAL EMERGENCY SERVICES, I | R | 8/19/2020 | 45.00 | | 047384 | | 45.00 | 02013 | B & C AUTO REPAIR | R | 9/15/2020 | 047457 | | 047457 | | 306.28 |
| 13280 | MAIN STREET MEDIA | R | 8/19/2020 | 1,763.00 | | 047385 | | 1,763.00 | 02060 | BARCO MUNICIPAL PRODUCTS INC. | R | 9/15/2020 | 047458 | | 047458 | | 343.14 |
| 20986 | UMB BANK | R | 8/19/2020 | 1,358.81 | | 047387 | | 1,358.81 | 02070 | BARTLETT & WEST, INC. | R | 9/15/2020 | 047459 | | 047459 | | 27,000.00 |
| 1 | JAMES MARKE | R | 8/19/2020 | 50.00 | | 047390 | | 50.00 | 02070 | BARTLETT & WEST, INC. | R | 9/15/2020 | 047460 | | 047460 | | 9,938.25 |
| 01996 | A/R/C-KANSAS, INC., SHEARS DIVI | R | 9/01/2020 | 196,687.42 | | 047411 | | 196,687.42 | 02070 | BARTLETT & WEST, INC. | R | 9/15/2020 | 047461 | | 047461 | | 19,465.55 |
| 02043 | COOKS AUTO PARTS LLC | R | 9/03/2020 | 806.76 | | 047412 | | 806.76 | 02070 | BARTLETT & WEST, INC. | R | 9/15/2020 | 047462 | | 047462 | | 55,250.00 |
| 08136 | HEARTLAND BUILDING CENTER, INC | R | 9/03/2020 | 71.81 | | 047414 | | 71.81 | 02148 | SCOTT SIMPSON | R | 9/15/2020 | 047463 | | 047463 | | 15,860.62 |
| 1 | RUSSELL PRINTERSTA | R | 9/03/2020 | 400.00 | | 047415 | | 400.00 | 1 | BETHEL ADAMS | R | 9/15/2020 | 047464 | | 047464 | | 246.89 |
| 13039 | OFFICE PRODUCTS, INC | R | 9/03/2020 | 2,799.00 | | 047416 | | 2,799.00 | 02170 | MARK A. BLEHM | R | 9/15/2020 | 047465 | | 047465 | | 500.00 |
| 19220 | WAREHOUSE, INC | R | 9/03/2020 | 172.12 | | 047419 | | 172.12 | 02305 | BUDGET PLUMBING HEATING - AIR | R | 9/15/2020 | 047466 | | 047466 | | 1,107.28 |
| 13410 | STANTON WHOLESALE ELECTRIC CO. | R | 9/03/2020 | 19,557.24 | | 047420 | | 19,557.24 | 02330 | BUSINESS PROTECTION EQUIPMENT | R | 9/15/2020 | 047467 | | 047467 | | 54.06 |
| 13500 | STOPEL SUPPLY CO., INC. | R | 9/03/2020 | 1,469.82 | | 047423 | | 1,469.82 | 26785 | CENTER STONEWORKS, LLC | R | 9/15/2020 | 047468 | | 047468 | | 314.70 |
| 26481 | UNDERGROUND VALUITS & STORAGE, | R | 9/03/2020 | 60.00 | | 047428 | | 60.00 | 03270 | CITY OF RUSSELL | R | 9/15/2020 | 047469 | | 047469 | | 1,270.26 |

9/09/2020 3:34 PM
 VENDOR SET: 01 City of Russell
 BANK: A/R/R POOL CASH ACCOUNT
 DATE RANGE: 8/19/2020 THRU 9/15/2020

A/P HISTORY CHECK REPORT

PAGE: 3

| VENOR I.D. | NAME | STATUS | CHECK DATE | INVOICE AMOUNT | DISCOUNT | CHECK NO | CHECK STATUS | CHECK AMOUNT | VENOR I.D. | NAME | STATUS | CHECK DATE | INVOICE AMOUNT | DISCOUNT | CHECK NO | CHECK STATUS | CHECK AMOUNT |
|------------|----------------------------------|--------|------------|----------------|----------|----------|--------------|--------------|------------|--------------------------------|--------|------------|----------------|----------|----------|--------------|--------------|
| 26510 | COMFORT PRO INC | R | 9/15/2020 | 5,404.00 | | 047470 | | 5,404.00 | 26671 | LAVAR TEXAS LIMITED PARTNERSHI | R | 9/15/2020 | 200.00 | | 047494 | | 200.00 |
| 1 | DAROLD GIBSON | R | 9/15/2020 | 50.00 | | 047471 | | 50.00 | 12160 | LAMFON WELDING SUPPLY CO, INC | R | 9/15/2020 | 70.12 | | 047495 | | 70.12 |
| 26782 | ENVIRONMENTAL SYSTEMS RESEARCH | R | 9/15/2020 | 2,750.00 | | 047472 | | 2,750.00 | 26527 | MICROV L TEBL | R | 9/15/2020 | 53.00 | | 047496 | | 53.00 |
| 13348 | ELECTRONS EATON MANUFACTCAL, LLC | R | 9/15/2020 | 690.00 | | 047473 | | 690.00 | 12091 | LAMSON PRODUCTS INC | R | 9/15/2020 | 34.65 | | 047497 | | 34.65 |
| 26638 | COSENT, INC | R | 9/15/2020 | 2,225.00 | | 047474 | | 2,225.00 | 26608 | DLAN J PAKRA | R | 9/15/2020 | 721.69 | | 047498 | | 721.69 |
| 07020 | GUIDE SALES COMPANY, INC. | R | 9/15/2020 | 445.20 | | 047475 | | 445.20 | 09869 | INTERPET INC | R | 9/15/2020 | 125.00 | | 047500 | | 125.00 |
| 07028 | GALLS, LLC | R | 9/15/2020 | 1,234.99 | | 047476 | | 1,234.99 | 13350 | MISSISSIPPI LINE COMPANY | R | 9/15/2020 | 5,471.97 | | 047501 | | 5,471.97 |
| 26672 | GARBARIT CALUMIAN COMPANY | R | 9/15/2020 | 1,848.00 | | 047478 | | 1,848.00 | 13315 | MONICPRAL SUPPLY INC | R | 9/15/2020 | 1,866.08 | | 047502 | | 1,866.08 |
| 26513 | JOSHUA L HANWACK | R | 9/15/2020 | 15.50 | | 047479 | | 15.50 | 26760 | ASSURECO RISK MANAGEMENT & RES | R | 9/15/2020 | 4,900.00 | | 047503 | | 4,900.00 |
| 26607 | GILMORE SOLUTIONS, INC | R | 9/15/2020 | 9,071.54 | | 047480 | | 9,071.54 | 14069 | NEX-TECH, LLC | R | 9/15/2020 | 2,639.67 | | 047504 | | 2,639.67 |
| 07116 | W.M. GRATINGER, INC | R | 9/15/2020 | 131.90 | | 047482 | | 131.90 | 14068 | NEX-TECH WIRELESS, LLC | R | 9/15/2020 | 437.14 | | 047505 | | 437.14 |
| 26526 | GREAT BEND COOPERATIVE ASSOCIA | R | 9/15/2020 | 6,169.83 | | 047483 | | 6,169.83 | 14199 | AUSTRALIS ENTERPRISES INC | R | 9/15/2020 | 89.28 | | 047507 | | 89.28 |
| 08020 | BACH COMPANY | R | 9/15/2020 | 635.36 | | 047484 | | 635.36 | 14190 | AUSTRALIS ENTERPRISES INC | R | 9/15/2020 | 30.00 | | 047508 | | 30.00 |
| 26307 | BHWKINS, INC | R | 9/15/2020 | 15,196.16 | | 047485 | | 15,196.16 | 26237 | DARRELL L. RYAN | R | 9/15/2020 | 4,450.00 | | 047509 | | 4,450.00 |
| 08129 | HELENA CHEMICAL COMPANY | R | 9/15/2020 | 1,178.30 | | 047486 | | 1,178.30 | 26473 | OPTV SECURITY | R | 9/15/2020 | 50.34 | | 047510 | | 50.34 |
| 09057 | INSURANCE PLANNING INC | R | 9/15/2020 | 21,351.00 | | 047487 | | 21,351.00 | 1 | PAUL POPE | R | 9/15/2020 | 50.00 | | 047511 | | 50.00 |
| 26757 | KANSAS ECONOMIC DEVELOPMENT AL | R | 9/15/2020 | 50.00 | | 047488 | | 50.00 | 16137 | THE PITNEY BOWES BANK INC | R | 9/15/2020 | 1,000.00 | | 047512 | | 1,000.00 |
| 11132 | KANSAS GOLF AND TURF, INC. | R | 9/15/2020 | 276.09 | | 047489 | | 276.09 | 16106 | POSTMASTER | R | 9/15/2020 | 240.00 | | 047513 | | 240.00 |
| 11115 | KANSAS ONE-CALL SYSTEM, INC | R | 9/15/2020 | 88.80 | | 047490 | | 88.80 | 16122 | PROFESSIONAL FIRE EQUIP CO, LL | R | 9/15/2020 | 96.00 | | 047514 | | 96.00 |
| 11175 | KEY EQUIPMENT & SUPPLY CO | R | 9/15/2020 | 862.31 | | 047491 | | 862.31 | 18250 | RUSSELL CO SHERIFF'S OFFI | R | 9/15/2020 | 270.00 | | 047515 | | 270.00 |
| 26632 | KRISTA L WHITNER | R | 9/15/2020 | 3,228.32 | | 047492 | | 3,228.32 | 18240 | RUSSELL CO SOLID WASTE | R | 9/15/2020 | 8,357.75 | | 047516 | | 8,357.75 |
| 26072 | KS STATE TREASURER | R | 9/15/2020 | 231.00 | | 047493 | | 231.00 | 19340 | RUSSELL READY MIX CONCRETE, IN | R | 9/15/2020 | 2,040.00 | | 047517 | | 2,040.00 |

9/09/2020 3:34 PM
 VENDOR SET: 01
 BANK: APBK
 DATE RANGE: 9/19/2020 THRU 9/15/2020

A/P HISTORY CHECK REPORT

PAGE: 6

9/09/2020 3:34 PM
 VENDOR SET: 01
 BANK: APBK
 DATE RANGE: 8/19/2020 THRU 9/15/2020

A/P HISTORY CHECK REPORT

PAGE: 7

| VENDOR I.D. | NAME | STATUS | CHECK DATE | INVOICE AMOUNT | DISCOUNT | CHECK NO | CHECK STATUS | CHECK AMOUNT | VENDOR I.D. | NAME | STATUS | CHECK DATE | INVOICE AMOUNT | DISCOUNT | CHECK NO | CHECK STATUS | CHECK AMOUNT |
|-------------|---------------------------------|--------|------------|----------------|----------|----------|--------------|--------------|-------------|--------------------------------|--------|------------|----------------|----------|----------|--------------|--------------|
| 18170 | WEST-CENTRAL KANSAS ASSOC INC | R | 9/15/2020 | 150.00 | | 047518 | | 150.00 | 26311 | SUNFLOWER USA CUSTODIAN FOR D | D | 8/28/2020 | 200.00 | | 000088 | | 200.00 |
| 19025 | SAGE PRODUCTS, INC. | R | 9/15/2020 | 92.55 | | 047519 | | 92.55 | 26371 | SUNFLOWER USA CUSTODIAN FOR A | D | 8/28/2020 | 200.00 | | 000089 | | 200.00 |
| 19080 | SALINA STEEL SUPPLY | R | 9/15/2020 | 262.36 | | 047520 | | 262.36 | 26401 | SUNFLOWER CUSTODIAN FOR T REIN | D | 8/28/2020 | 50.00 | | 000090 | | 50.00 |
| 19220 | SIRCHIE ACQUISITION COMPANY LLC | R | 9/15/2020 | 111.95 | | 047521 | | 111.95 | 01141 | AMER. FIDELITY ASSURANCE | D | 8/26/2020 | 1,226.76 | | 000488 | | 1,226.76 |
| 19252 | SOLONON TRANSPORTERS, LLC | R | 9/15/2020 | 29.00 | | 047522 | | 29.00 | 01142 | AMER. FIDELITY ASSURANCE | D | 8/26/2020 | 1,787.32 | | 000489 | | 1,787.32 |
| 26744 | SIEZ WTS SOLUTIONS USA, INC | R | 9/15/2020 | 5,955.00 | | 047523 | | 5,955.00 | 01143 | AMERICAN FIDELITY ASSURANCE CO | D | 8/26/2020 | 1,387.16 | | 000490 | | 1,387.16 |
| 26734 | TANTALUS SYSTEMS INC | R | 9/15/2020 | 8,400.00 | | 047524 | | 8,400.00 | | BANK UNITED | D | 8/26/2020 | 34,713.89 | | 000491 | | 34,713.89 |
| 20044 | THYSSENKRUPP ELEVATOR CORPORA | R | 9/15/2020 | 206.57 | | 047525 | | 206.57 | | GREATWEST FINANCIAL | D | 8/26/2020 | 1,620.00 | | 000492 | | 1,620.00 |
| 26724 | TIRE CITY, LLC | R | 9/15/2020 | 83.45 | | 047526 | | 83.45 | | K P E R S | D | 8/26/2020 | 23,086.71 | | 000493 | | 23,086.71 |
| 26763 | OHARA TRUCK CENTER COMPANY, IN | R | 9/15/2020 | 90.23 | | 047527 | | 90.23 | 11015 | KS DEPT OF REVENUE | D | 8/26/2020 | 5,711.92 | | 000494 | | 5,711.92 |
| 26105 | TTLER TECHNOLOGIES INC. | R | 9/15/2020 | 11,445.00 | | 047528 | | 11,445.00 | | LEGAL SHIELD | D | 8/26/2020 | 287.90 | | 000495 | | 287.90 |
| 20986 | UMB BANK | R | 9/15/2020 | 801.08 | | 047529 | | 801.08 | 21042 | BANK UNITED | D | 9/09/2020 | 34,588.65 | | 000504 | | 34,588.65 |
| 22011 | VAN DIEET SUPPLY COMPANY | R | 9/15/2020 | 253.40 | | 047531 | | 253.40 | 09032 | GREATWEST FINANCIAL | D | 9/09/2020 | 1,720.00 | | 000505 | | 1,720.00 |
| 26135 | VERIZON WIRELESS SERVICES LLC- | R | 9/15/2020 | 415.60 | | 047532 | | 415.60 | 11010 | K P E R S | D | 9/09/2020 | 22,740.63 | | 000506 | | 22,740.63 |
| 26754 | WHITENATER WEST INDUSTRIES LTD | R | 9/15/2020 | 2,500.00 | | 047533 | | 2,500.00 | 11011 | K P E R S LIFE INSURANCE | D | 9/09/2020 | 628.85 | | 000507 | | 628.85 |
| 26621 | B.A.T.S., INC | R | 9/15/2020 | 284.85 | | 047534 | | 284.85 | 11015 | KS DEPT OF REVENUE | D | 9/09/2020 | 5,727.19 | | 000508 | | 5,727.19 |
| | | | | | | | | | 03282 | CITY OF RUSSELL | R | 8/26/2020 | 5,439.97 | | 047407 | | 5,439.97 |
| | | | | | | | | | 11002 | KANSAS PAYMENT CENTER | R | 8/26/2020 | 537.70 | | 047409 | | 537.70 |
| | | | | | | | | | 26728 | TX CHILD SUPPORT SDU | R | 8/26/2020 | 306.93 | | 047410 | | 306.93 |
| | | | | | | | | | 03282 | CITY OF RUSSELL | R | 9/09/2020 | 5,439.97 | | 047440 | | 5,439.97 |
| | | | | | | | | | 11002 | KANSAS PAYMENT CENTER | R | 9/09/2020 | 537.70 | | 047442 | | 537.70 |
| | | | | | | | | | 26728 | TX CHILD SUPPORT SDU | R | 9/09/2020 | 306.93 | | 047443 | | 306.93 |

*** T O T A L S ***

REGULAR CHECKS: 95 NO INVOICE AMOUNT DISCOUNTS CHECK AMOUNT 11002

HAND CHECKS: 0 0.00 0.00 659,505.76 26728

DRAFTS: 9 0.00 0.00 495,357.71 03282

NON CHECKS: 0 0.00 0.00 0.00 11002

VOID CHECKS: 0 VOID DEBITS 0.00 0.00 26728

VOID CREDITS 0.00 0.00

TOTAL ERRORS: 0

VENDOR SET: 01 BANK: APBK TOTALS: NO INVOICE AMOUNT DISCOUNTS CHECK AMOUNT

104 1,153,863.47 0.00 1,153,863.47

BANK: APBK TOTALS: 104 1,153,863.47 0.00 1,153,863.47

9/09/2020 3:34 PM
 VENDOR SET: 01 City of Russell
 BANK: PYBK PAYROLL ACCOUNT
 DATE RANGE: 8/19/2020 THRU 9/15/2020

A/P HISTORY CHECK REPORT

PAGE: 1

| VENDOR I.D. | NAME | STATUS | CHECK DATE | INVOICE AMOUNT | DISCOUNT | CHECK NO | CHECK STATUS | CHECK AMOUNT |
|---------------------|-----------------|---------|------------|----------------|----------|----------|--------------|--------------|
| * * T O T A L S * * | | | | | | | | |
| | REGULAR CHECKS: | | | 12,569.20 | 0.00 | 6 | | 12,569.20 |
| | HAND CHECKS: | | | 0.00 | 0.00 | 0 | | 0.00 |
| | DRAFTS: | | | 135,226.98 | 0.00 | 13 | | 135,226.98 |
| | EFT: | | | 550.00 | 0.00 | 3 | | 550.00 |
| | NON CHECKS: | | | 0.00 | 0.00 | 0 | | 0.00 |
| | VOID CHECKS: | | | 0.00 | 0.00 | 0 | | 0.00 |
| | VOID DEBITS | | | 0.00 | 0.00 | 0 | | 0.00 |
| | VOID CREDITS | | | 0.00 | 0.00 | 0 | | 0.00 |
| TOTAL ERRORS: 0 | | | | | | | | |
| VENDOR SET: 01 | BANK: PYBK | TOTALS: | | 148,346.18 | 0.00 | 22 | | 148,346.18 |
| BANK: PYBK | TOTALS: | | | 148,346.18 | 0.00 | 22 | | 148,346.18 |
| REPORT TOTALS: | | | | 1,302,209.65 | 0.00 | 126 | | 1,302,209.65 |

VENDOR SET: 01 City of Russell
 BANK: APBK POOL CASH ACCOUNT
 DATE RANGE: 8/19/2020 THRU 9/15/2020

| VENDOR I.D. | NAME | STATUS | CHECK DATE | INVOICE AMOUNT | DISCOUNT | CHECK NO | CHECK STATUS | CHECK AMOUNT |
|-------------------|--------------------------------|--------|------------|----------------|----------|----------|--------------|--------------|
| 11101 | KS DEPARTMENT OF REVENUE | | | | | | | |
| I-202008213921 | KS DEPARTMENT OF REVENUE | D | 8/25/2020 | 21,005.56 | | 000487 | | 21,005.56 |
| 11114 | KMEA - EMP 2 OPERATING ACCT | | | | | | | |
| I-WAPA-RU-20-08 | WAPA-RU-20-08 | D | 9/04/2020 | 46,989.58 | | 000498 | | 46,989.58 |
| 11114 | KMEA - EMP 2 OPERATING ACCT | | | | | | | |
| I-GRDA-RU-20-09 | GRDA-RU-20-09 | D | 9/03/2020 | 61,543.25 | | 000499 | | 61,543.25 |
| 11114 | KMEA - EMP 2 OPERATING ACCT | | | | | | | |
| I-EMP2-RU-2020-07 | EMP2-RU-2020-07 | D | 8/20/2020 | 287,448.01 | | 000500 | | 287,448.01 |
| 11114 | KMEA - EMP 2 OPERATING ACCT | | | | | | | |
| I-202009013933 | KMEA-DG-RU-20-0 | D | 8/26/2020 | 70,044.23 | | 000502 | | 70,044.23 |
| 01996 | APAC-KANSAS, INC., SHEARS DIVI | | | | | | | |
| I-202008313926 | MAPLE/ST JOHN PROJECT | R | 9/01/2020 | 196,687.42 | | 047411 | | 196,687.42 |
| 19410 | STANION WHOLESALE ELECTRIC CO. | | | | | | | |
| C-202009013932 | EARLY PAY DISCOUNT | R | 9/03/2020 | 114,67CR | | 047420 | | |
| I-4946431-02 | INV. PARTS | R | 9/03/2020 | 282.92 | | 047420 | | |
| I-4950025-02 | INV. PARTS | R | 9/03/2020 | 405.58 | | 047420 | | |
| I-4958067-02 | INV PARTS AND EXTENDOSTIK | R | 9/03/2020 | 110.67 | | 047420 | | |
| I-4964957-01 | INV. PARTS WOOD DRILLBITS | R | 9/03/2020 | 66.42 | | 047420 | | |
| I-4964957-02 | INV. PARTS WOOD DRILLBITS | R | 9/03/2020 | 849.28 | | 047420 | | |
| I-4968929-02 | INV. PARTS | R | 9/03/2020 | 26.56 | | 047420 | | |
| I-4975117-00 | POLE 120/240V/ FRONT FILLER PL | R | 9/03/2020 | 48.93 | | 047420 | | |
| I-4976092-00 | LED STREET LIGHTS | R | 9/03/2020 | 420.67 | | 047420 | | |
| I-4976092-01 | LED STREET LIGHTS | R | 9/03/2020 | 926.05 | | 047420 | | |
| I-4976702-00 | INV PARTS | R | 9/03/2020 | 2,177.02 | | 047420 | | |
| I-4976889-00 | LED STREET LIGHTS | R | 9/03/2020 | 5,822.40 | | 047420 | | |
| I-4978639-00 | POLE/BACK MOUNTING PLATE SCREW | R | 9/03/2020 | 142.62 | | 047420 | | |
| I-4978860-00 | PLC 5 BATTERY | R | 9/03/2020 | 322.40 | | 047420 | | |
| I-4980721-00 | INV PARTS | R | 9/03/2020 | 585.36 | | 047420 | | |
| I-4980721-01 | INV PARTS | R | 9/03/2020 | 282.92 | | 047420 | | |
| I-4986333-00 | INV PARTS | R | 9/03/2020 | 33.67 | | 047420 | | |
| I-4986333-01 | INV PARTS | R | 9/03/2020 | 2,033.73 | | 047420 | | |
| I-4986333-02 | INV PARTS | R | 9/03/2020 | 811.15 | | 047420 | | |
| I-4986333-05 | INV PARTS | R | 9/03/2020 | 565.85 | | 047420 | | |
| I-4987657-00 | LOADCENTER/CHF BREAKER | R | 9/03/2020 | 49.90 | | 047420 | | |
| I-4988721-00 | INV PARTS | R | 9/03/2020 | 1,075.81 | | 047420 | | |
| I-4988721-01 | INV PARTS | R | 9/03/2020 | 2,267.66 | | 047420 | | |
| I-4990158-00 | INSLATROO | R | 9/03/2020 | 257.08 | | 047420 | | |
| I-4992645-00 | BOLT OVAL EYE/VINYL ELECT TAPE | R | 9/03/2020 | 107.26 | | 047420 | | 19,557.24 |

| VENDOR I.D. | NAME | STATUS | CHECK DATE | INVOICE AMOUNT | DISCOUNT | CHECK NO | CHECK STATUS | CHECK AMOUNT |
|---------------------------------------|---|--------|------------------------|----------------------|----------|------------------|--------------|--------------|
| 01996 I-202009043937 | APAC-KANSAS, INC., SHEARS DIVI MAPLE/ST JOHN PROJECT | R | 9/15/2020 | 149,912.55 | | 047454 | | 149,912.55 |
| 02070 I-730076815 | BARTLETT & WEST, INC. PROFESSIONAL SERVICES | R | 9/15/2020 | 27,000.00 | | 047459 | | 27,000.00 |
| 02070 I-730076941 | BARTLETT & WEST, INC., SERVICES AGREEMENT | R | 9/15/2020 | 19,465.55 | | 047461 | | 19,465.55 |
| 02070 I-730076943 | BARTLETT & WEST, INC., SERVICES AGREEMENT | R | 9/15/2020 | 55,250.00 | | 047462 | | 55,250.00 |
| 02148 I-64845 | SCOTT SIMPSON REPAIRING RADIATOR | R | 9/15/2020 | 15,860.62 | | 047463 | | 15,860.62 |
| 26307 I-4773516 I-4778729 | HAWKINS, INC SODA ASH DENSE TREATMENT CHEMICALS | R R | 9/15/2020 9/15/2020 | 9,839.72 5,356.44 | | 047485 047485 | | 15,196.16 |
| 09057 I-972652 I-973530 | INSURANCE PLANNING INC ADD 2019 CHEVY #7185 BOILER & MACHINERY | R R | 9/15/2020 9/15/2020 | 644.00 20,707.00 | | 047487 047487 | | 21,351.00 |
| 26105 I-025-308344 I-025-308586 | TYLER TECHNOLOGIES INC. UTILITY METER DATA SYNC UTILITY METER DATA SYNC | R R | 9/15/2020 9/15/2020 | 11,250.00 195.00 | | 047528 047528 | | 11,445.00 |

| * * T O T A L S * * | NO | INVOICE AMOUNT | DISCOUNTS | CHECK AMOUNT |
|---------------------|----|---------------------------------------|-----------|--------------|
| REGULAR CHECKS: | 10 | 531,725.54 | 0.00 | 531,725.54 |
| HAND CHECKS: | 0 | 0.00 | 0.00 | 0.00 |
| DRAFTS: | 5 | 487,030.63 | 0.00 | 487,030.63 |
| EFT: | 0 | 0.00 | 0.00 | 0.00 |
| NON CHECKS: | 0 | 0.00 | 0.00 | 0.00 |
| VOID CHECKS: | 0 | VOID DEBITS 0.00 VOID CREDITS 0.00 | 0.00 | 0.00 |

TOTAL ERRORS: 0

| VENDOR SET: 01 BANK: APBK TOTALS: | NO | INVOICE AMOUNT | DISCOUNTS | CHECK AMOUNT |
|-----------------------------------|----|----------------|-----------|--------------|
| BANK: APBK TOTALS: | 15 | 1,018,756.17 | 0.00 | 1,018,756.17 |

VENDOR SET: 01 City of Russell
 BANK: PYBK PAYROLL ACCOUNT
 DATE RANGE: 8/19/2020 THRU 9/15/2020

| VENDOR I.D. | NAME | STATUS | CHECK DATE | INVOICE AMOUNT | DISCOUNT | CHECK NO | CHECK STATUS | CHECK AMOUNT |
|-------------------|-----------------------------|--------|------------|----------------|----------|----------|--------------|--------------|
| 21042 | BANK UNITED | | | | | | | |
| I-T1 202008253922 | FEDERAL WITHHOLDING | D | 8/26/2020 | 12,306.75 | | 000491 | | |
| I-T3 202008253922 | FICA WITHHOLDING | D | 8/26/2020 | 18,160.04 | | 000491 | | |
| I-T4 202008253922 | MEDICARE WITHHOLDING | D | 8/26/2020 | 4,247.10 | | 000491 | | 34,713.89 |
| 11010 | K P E R S | | | | | | | |
| I-RE2202008253922 | EMPLOYEE/EMPLOYER KPERS W/H | D | 8/26/2020 | 4,305.58 | | 000493 | | |
| I-RET202008253922 | EMPLOYEE/EMPLOYER KPERS W/H | D | 8/26/2020 | 9,520.69 | | 000493 | | |
| I-RT3202008253922 | EMPLOYEE/EMPLOYER KPERS | D | 8/26/2020 | 9,260.44 | | 000493 | | 23,086.71 |
| 21042 | BANK UNITED | | | | | | | |
| I-T1 202009083939 | FEDERAL WITHHOLDING | D | 9/09/2020 | 12,476.79 | | 000504 | | |
| I-T3 202009083939 | FICA WITHHOLDING | D | 9/09/2020 | 17,920.78 | | 000504 | | |
| I-T4 202009083939 | MEDICARE WITHHOLDING | D | 9/09/2020 | 4,191.08 | | 000504 | | 34,588.65 |
| 11010 | K P E R S | | | | | | | |
| I-RE2202009083939 | EMPLOYEE/EMPLOYER KPERS W/H | D | 9/09/2020 | 4,214.66 | | 000506 | | |
| I-RET202009083939 | EMPLOYEE/EMPLOYER KPERS W/H | D | 9/09/2020 | 9,464.69 | | 000506 | | |
| I-RT3202009083939 | EMPLOYEE/EMPLOYER KPERS | D | 9/09/2020 | 9,061.28 | | 000506 | | 22,740.63 |

| * * T O T A L S * * | | NO | INVOICE AMOUNT | DISCOUNTS | CHECK AMOUNT |
|---------------------|--------------|----|----------------|-----------|--------------|
| REGULAR CHECKS: | | 0 | 0.00 | 0.00 | 0.00 |
| HAND CHECKS: | | 0 | 0.00 | 0.00 | 0.00 |
| DRAFTS: | | 4 | 115,129.88 | 0.00 | 115,129.88 |
| EFT: | | 0 | 0.00 | 0.00 | 0.00 |
| NON CHECKS: | | 0 | 0.00 | 0.00 | 0.00 |
| VOID CHECKS: | | 0 | 0.00 | 0.00 | 0.00 |
| | VOID DEBITS | | 0.00 | | |
| | VOID CREDITS | | 0.00 | 0.00 | 0.00 |

TOTAL ERRORS: 0

| VENDOR SET: 01 | BANK: PYBK | TOTALS: | NO | INVOICE AMOUNT | DISCOUNTS | CHECK AMOUNT |
|----------------|------------|---------|----|----------------|-----------|--------------|
| | | | 4 | 115,129.88 | 0.00 | 115,129.88 |
| BANK: PYBK | TOTALS: | | 4 | 115,129.88 | 0.00 | 115,129.88 |
| REPORT TOTALS: | | | 4 | 115,129.88 | 0.00 | 1,133,886.05 |

POOLED CASH REPORT

AS OF: AUGUST 31ST, 2020

| FUND | ACCOUNT# | ACCOUNT NAME | BEGINNING BALANCE | CURRENT ACTIVITY | CURRENT BALANCE |
|----------------------|----------|--------------------------------|----------------------|---------------------|--------------------|
| <u>CLAIM ON CASH</u> | | | | | |
| 10 | 100 | GENERAL - CLAIM ON CASH | 2,511,794.60 | (280,877.27) | 2,230,917.33 |
| 12 | 100 | AIRPORT - CLAIM ON CASH | 83,677.11 | (4,367.22) | 79,309.89 |
| 16 | 100 | INDUSTRIAL - CLAIM ON CASH | 86,967.28 | 2,484.95 | 89,452.23 |
| 18 | 100 | BOND & INT - CLAIM ON CASH | 121,929.50 | 142.00 | 122,071.50 |
| 22 | 100 | LIBRARY - CLAIM ON CASH | 0.00 | 0.00 | 0.00 |
| 24 | 100 | FIRE EQUIP - CLAIM ON CASH | 112,735.27 | 132.00 | 112,867.27 |
| 26 | 100 | RECREATION - CLAIM ON CASH | 0.00 | 0.00 | 0.00 |
| 27 | 100 | REC EMP BEN - CLAIM ON CASH | 0.00 | 0.00 | 0.00 |
| 28 | 100 | PERS BENEFITS - CLAIM ON CASH | 855,518.08 | (123,639.92) | 731,878.16 |
| 29 | 100 | SPECIAL HWY - CLAIM ON CASH | 215,702.43 | (15,562.00) | 200,140.43 |
| 36 | 100 | ELECTRIC - CLAIM ON CASH | 7,804,178.17 | 303,086.75 | 8,107,264.92 |
| 37 | 100 | WTR IMPROV - CLAIM ON CASH | 1,406,314.17 | (78,484.14) | 1,327,830.03 |
| 38 | 100 | WATER - CLAIM ON CASH | 2,363,728.93 | 139,967.16 | 2,503,696.09 |
| 39 | 100 | SANITATION - CLAIM ON CASH | 467,736.53 | 26,139.66 | 493,876.19 |
| 40 | 100 | ELEC DEPR - CLAIM ON CASH | 1,750,493.72 | 95.30 | 1,750,589.02 |
| 43 | 100 | IND PARK TIF - CLAIM ON CASH | 0.00 | 0.00 | 0.00 |
| 45 | 100 | WW REPLACEMENT - CLAIM ON CASH | 678,940.68 | 792.00 | 679,732.68 |
| 46 | 100 | WASTEWATER - CLAIM ON CASH | 867,111.16 | 33,166.98 | 900,278.14 |
| 47 | 100 | SPECIAL PARK - CLAIM ON CASH | 64,163.17 | 75.00 | 64,238.17 |
| 48 | 100 | SANIT REPL - CLAIM ON CASH | 293,016.50 | 342.00 | 293,358.50 |
| 51 | 100 | CAPITAL IMPROV -CLAIM ON CASH | 706,423.81 | 160,474.53 | 866,898.34 |
| 52 | 100 | EQUIP RESERVE - CLAIM ON CASH | 342,518.37 | (21,595.81) | 320,922.56 |
| 61 | 100 | COURT - CLAIM ON CASH | 8,648.92 | (819.52) | 7,829.40 |
| 65 | 100 | EDA GRANT - CLAIM ON CASH | 0.00 | 0.00 | 0.00 |
| 70 | 100 | AIRPORT IMPROV - CLAIM ON CASH | 0.00 | 0.00 | 0.00 |
| 71 | 100 | WICHITA AVE - CLAIM ON CASH | 0.00 | 0.00 | 0.00 |
| 80 | 100 | HEALTH INS - CLAIM ON CASH | 286,524.63 | (61,137.34) | 225,387.29 |
| 81 | 100 | GOLF COURSE IMPR-CLAIM ON CASH | 40,826.14 | 123.00 | 40,949.14 |
| 82 | 100 | SINK OR SWIM - CLAIM ON CASH | 977.75 | 1.00 | 978.75 |
| 83 | 100 | FIRE INS PROC - CLAIM ON CASH | 0.00 | 0.00 | 0.00 |
| 84 | 100 | RISK MGT RES - CLAIM ON CASH | 20,994.60 | 25.00 | 21,019.60 |
| 85 | 100 | DRUG FORFEITURE -CLAIM ON CASH | 3,713.78 | 4.00 | 3,717.78 |
| 86 | 100 | JOHNSON TRUST - CLAIM ON CASH | 901,716.47 | 1,052.00 | 902,768.47 |
| 87 | 100 | FIREFIGHTER AC -CLAIM ON CASH | 17,002.89 | (711.71) | 16,291.18 |
| 89 | 100 | DCC TRUST - CLAIM ON CASH | 25,022.08 | 29.00 | 25,051.08 |
| 90 | 100 | DONATIONS - CLAIM ON CASH | 9,068.84 | 0.00 | 9,068.84 |
| TOTAL CLAIM ON CASH | | | 22,047,445.58 | 80,937.40 | 22,128,382.98 |

CASH IN BANK - POOLED CASH

| | | | | | |
|----|-----|-------------------------------|--------------|---------------|--------------|
| 99 | 100 | POOL CASH - CHECKING | 8,066,584.99 | 103,414.63 | 8,169,999.62 |
| 99 | 101 | MONEY MARKET ACCT | 1,151,990.63 | 195.68 | 1,152,186.31 |
| 99 | 102 | SUNFLOWER BANK | 340,124.58 | (61,137.34) | 278,987.24 |
| 99 | 103 | UMB INVESTMENTS | 6,509,005.95 | 200,582.46 | 6,709,588.41 |
| 99 | 104 | UMB CHECKING | 577,330.54 | (186,379.07) | 390,951.47 |
| 99 | 105 | KMIP INVESTMENTS | 3,746,552.54 | 23,427.57 | 3,769,980.11 |
| 99 | 106 | UNB INVESTMENTS | 0.00 | 0.00 | 0.00 |
| 99 | 107 | WILSON STATE BANK INVESTMENTS | 1,653,356.35 | 833.47 | 1,654,189.82 |

POOLED CASH REPORT

AS OF: AUGUST 31ST, 2020

| FUND | ACCOUNT# | ACCOUNT NAME | BEGINNING BALANCE | CURRENT ACTIVITY | CURRENT BALANCE |
|---|----------|-----------------------------|----------------------|---------------------|--------------------|
| 99 | 108 | CASH ON HAND & IMPREST | 2,500.00 | 0.00 | 2,500.00 |
| 99 | 109 | UNB CHECKING GRANT PROCEEDS | 0.00 | 0.00 | 0.00 |
| SUBTOTAL CASH IN BANK - POOLED CASH | | | 22,047,445.58 | 80,937.40 | 22,128,382.98 |
| <u>WAGES PAYABLE</u> | | | | | |
| 99 | 201 | WAGES PAYABLE | 0.00 | 0.00 | 0.00 |
| SUBTOTAL WAGES PAYABLE | | | 0.00 | 0.00 | 0.00 |
| TOTAL CASH IN BANK - POOLED CASH | | | 22,047,445.58 | 80,937.40 | 22,128,382.98 |
| <u>DUE TO OTHER FUNDS - POOLED CASH</u> | | | | | |
| 99 | 205 | DUE TO OTHER FUNDS | 22,047,445.58 | 80,937.40 | 22,128,382.98 |
| TOTAL DUE TO OTHER FUNDS | | | 22,047,445.58 | 80,937.40 | 22,128,382.98 |

REVENUE & EXPENSE REPORT

AS OF: AUGUST 31ST, 2020

10 -GENERAL FUND
FINANCIAL SUMMARY

| | CURRENT BUDGET | CURRENT PERIOD | PRIOR YEAR PO ADJUST. | Y-T-D ACTUAL | Y-T-D ENCUMBRANCE | BUDGET BALANCE | % OF BUDGET |
|--|-------------------|-------------------|--------------------------|-----------------|----------------------|-------------------|----------------|
| <u>REVENUE SUMMARY</u> | | | | | | | |
| BUDGETED CASH CARRYOVER | 0.00 | 0.00 | 0.00 | 0.00 | 0.00 | 0.00 | 0.00 |
| LOCAL TAXES | 1,453,351.00 | 44,964.08 | 0.00 | 1,249,170.49 | 0.00 | 204,180.51 | 85.95 |
| STATE/FEDERAL REVENUE | 612,961.00 | 35,585.00 | 0.00 | 343,070.71 | 0.00 | 269,890.29 | 55.97 |
| PERMITS & LICENSE FEES | 35,500.00 | 3,664.00 | 0.00 | 26,721.00 | 0.00 | 8,779.00 | 75.27 |
| FRANCHISE FEES | 155,000.00 | 9,349.38 | 0.00 | 138,393.97 | 0.00 | 16,606.03 | 89.29 |
| RECREATION FEES | 80,650.00 | 8,398.00 | 0.00 | 70,424.70 | 0.00 | 10,225.30 | 87.32 |
| OTHER REVENUE | 360,456.00 | 32,702.74 | 0.00 | 256,295.33 | 0.00 | 104,160.67 | 71.10 |
| INVESTMENT REVENUE | 28,000.00 | 2,635.14 | 0.00 | 13,072.27 | 0.00 | 14,927.73 | 46.69 |
| TRANSFERS | 770,000.00 | 0.00 | 0.00 | 448,852.00 | 0.00 | 321,148.00 | 58.29 |
| *** TOTAL REVENUES *** | 3,495,918.00 | 137,298.34 | 0.00 | 2,546,000.47 | 0.00 | 949,917.53 | 72.83 |
| <u>EXPENDITURE SUMMARY</u> | | | | | | | |
| ADMINISTRATION | 2,222,221.00 | 171,363.73 | 0.00 | 337,802.76 | 0.00 | 1,884,418.24 | 15.20 |
| AMORY BUILDING | 10,800.00 | 0.00 | 0.00 | 5,492.45 | 0.00 | 5,307.55 | 50.86 |
| MAYOR/COUNCIL | 39,525.00 | 43.96 | 84.23 | 31,518.19 | 5,176.50 | 2,914.54 | 92.63 |
| CITY MANAGER | 162,199.00 | 9,728.86 | 84.23 | 97,859.42 | 0.00 | 64,423.81 | 60.28 |
| CITY CLERK | 197,828.00 | 40,190.37 | 0.00 | 150,211.01 | 1,061.30 | 46,555.69 | 76.47 |
| TRANSPORTATION/(BUS) | 73,588.00 | 3,735.84 | 84.22 | 37,673.50 | 0.00 | 35,998.72 | 51.08 |
| POLICE | 581,323.00 | 37,093.65 | 2,335.05 | 354,414.57 | 0.00 | 229,243.48 | 60.57 |
| PUBLIC WORKS | 90,406.00 | 6,243.56 | 146.72 | 57,776.03 | 0.00 | 32,776.69 | 63.75 |
| FIRE | 207,985.00 | 11,709.52 | 629.00 | 123,675.56 | 7,380.00 | 77,558.44 | 62.71 |
| MUNICIPAL COURT | 60,419.00 | 5,806.03 | 0.00 | 36,537.83 | 0.00 | 23,881.17 | 60.47 |
| 911 | 455,927.00 | 33,422.34 | 84.22 | 280,202.71 | 0.00 | 175,808.51 | 61.44 |
| COMMUNITY DEVELOPMENT | 165,926.00 | 11,679.81 | 84.21 | 97,441.66 | 0.00 | 68,568.55 | 58.68 |
| STREET | 354,504.00 | 32,984.16 | 7,059.24 | 249,034.05 | 6,184.00 | 106,345.19 | 70.00 |
| GOLF COURSE | 198,209.00 | 13,967.26 | 130.00 | 124,680.68 | 1,518.02 | 72,140.30 | 63.60 |
| GOLF CLUB HOUSE | 0.00 | 0.00 | 0.00 | 36.31 | 0.00 | 36.31 | 0.00 |
| SWIMMING POOL | 117,950.00 | 10,346.63 | 0.00 | 48,370.06 | 2,500.00 | 67,079.94 | 43.13 |
| PARK | 246,840.00 | 18,531.44 | 704.56 | 162,742.17 | 0.00 | 84,802.39 | 65.64 |
| DEINES CULTURAL CENTER | 48,847.00 | 2,479.69 | 0.00 | 30,193.45 | 0.00 | 18,653.55 | 61.81 |
| *** TOTAL EXPENDITURES *** | 5,234,497.00 | 409,326.85 | 11,425.68 | 2,225,589.79 | 23,819.82 | 2,996,513.07 | 42.75 |
| ** REVENUE OVER (UNDER) EXPENDITURES * | (1,738,579.00) | (272,028.51) | 11,425.68 | 320,410.68 | (23,819.82) | (2,046,595.54) | 117.72 |

REVENUE & EXPENSE REPORT

AS OF: AUGUST 31ST, 2020

28 -PERSONNEL BENEFITS FUND

FINANCIAL SUMMARY

| | CURRENT BUDGET | CURRENT PERIOD | PRIOR YEAR PO ADJUST. | Y-T-D ACTUAL | Y-T-D ENCUMBRANCE | BUDGET BALANCE | % OF BUDGET |
|--|-------------------|-------------------|--------------------------|-----------------|----------------------|-------------------|----------------|
| <u>REVENUE SUMMARY</u> | | | | | | | |
| BUDGETED CASH CARRYOVER | 0.00 | 0.00 | 0.00 | 0.00 | 0.00 | 0.00 | 0.00 |
| LOCAL TAXES | 573,445.00 | 0.00 | 0.00 | 512,634.57 | 0.00 | 60,810.43 | 89.40 |
| STATE/FEDERAL REVENUE | 0.00 | 0.00 | 0.00 | 0.00 | 0.00 | 0.00 | 0.00 |
| OTHER REVENUE | 125,891.00 | 5,935.36 | 0.00 | 72,151.99 | 0.00 | 53,739.01 | 57.31 |
| INVESTMENT REVENUE | 9,800.00 | 853.00 | 0.00 | 4,557.00 | 0.00 | 5,243.00 | 46.50 |
| TRANSFERS | 984,200.00 | 0.00 | 0.00 | 568,035.00 | 0.00 | 416,165.00 | 57.72 |
| *** TOTAL REVENUES *** | 1,693,336.00 | 6,788.36 | 0.00 | 1,157,378.56 | 0.00 | 535,957.44 | 68.35 |
| <u>EXPENDITURE SUMMARY</u> | | | | | | | |
| NON DEPARTMENTAL | 2,048,829.00 | 130,428.28 | 0.00 | 1,089,215.71 | 0.00 | 959,613.29 | 53.16 |
| *** TOTAL EXPENDITURES *** | 2,048,829.00 | 130,428.28 | 0.00 | 1,089,215.71 | 0.00 | 959,613.29 | 53.16 |
| ** REVENUE OVER (UNDER) EXPENDITURES * | (355,493.00) | (123,639.92) | 0.00 | 68,162.85 | 0.00 | (423,655.85) | 119.17 |

REVENUE & EXPENSE REPORT

AS OF:AUGUST 31ST, 2020

36 -ELECTRIC FUND
FINANCIAL SUMMARY

| | CURRENT BUDGET | CURRENT PERIOD | PRIOR YEAR PO ADJUST. | Y-T-D ACTUAL | Y-T-D ENCUMBRANCE | BUDGET BALANCE | % OF BUDGET |
|---|-------------------|-------------------|--------------------------|-----------------|----------------------|-------------------|----------------|
| <u>REVENUE SUMMARY</u> | | | | | | | |
| BUDGETED CASH CARRYOVER | 0.00 | 0.00 | 0.00 | 0.00 | 0.00 | 0.00 | 0.00 |
| STATE/FEDERAL REVENUE | 0.00 | 0.00 | 0.00 | 0.00 | 0.00 | 0.00 | 0.00 |
| UTILITY REVENUE | 10,221,457.00 | 796,837.05 | 0.00 | 6,108,407.79 | 0.00 | 4,113,049.21 | 59.76 |
| OTHER REVENUE | 0.00 | 0.00 | 0.00 | 0.00 | 0.00 | 0.00 | 0.00 |
| INVESTMENT REVENUE | 60,000.00 | 9,449.00 | 0.00 | 43,589.00 | 0.00 | 16,411.00 | 72.65 |
| TRANSFERS | 0.00 | 0.00 | 0.00 | 0.00 | 0.00 | 0.00 | 0.00 |
| *** TOTAL REVENUES *** | 10,281,457.00 | 806,286.05 | 0.00 | 6,151,996.79 | 0.00 | 4,129,460.21 | 59.84 |
| <u>EXPENDITURE SUMMARY</u> | | | | | | | |
| ADMINISTRATION | 1,530,620.00 | 18,325.63 | 0.00 | 690,901.12 | 0.00 | 839,718.88 | 45.14 |
| ELECTRIC PRODUCTION | 7,363,548.00 | 219,027.17 | 8,680.13 | 3,526,571.57 | 9,718.90 | 3,835,937.66 | 47.91 |
| ELECTRIC DISTRIBUTION | 818,735.00 | 49,615.82 | 49,436.22 | 491,577.12 | 3,437.55 | 373,156.55 | 54.42 |
| *** TOTAL EXPENDITURES *** | 9,712,903.00 | 286,968.62 | 58,116.35 | 4,709,049.81 | 13,156.45 | 5,048,813.09 | 48.02 |
| ** REVENUE OVER (UNDER) EXPENDITURES ** | 568,554.00 | 519,317.43 | 58,116.35 | 1,442,946.98 | (13,156.45) | (919,352.88) | 161.70- |

REVENUE & EXPENSE REPORT

AS OF: AUGUST 31ST, 2020

38 -WATER FUND
FINANCIAL SUMMARY

| | CURRENT BUDGET | CURRENT PERIOD | PRIOR YEAR PO ADJUST. | Y-T-D ACTUAL | Y-T-D ENCUMBRANCE | BUDGET BALANCE | % OF BUDGET |
|--|----------------------|-------------------|--------------------------|---------------------|----------------------|----------------------|----------------|
| <u>REVENUE SUMMARY</u> | | | | | | | |
| BUDGETED CASH CARRYOVER | 0.00 | 0.00 | 0.00 | 0.00 | 0.00 | 0.00 | 0.00 |
| STATE/FEDERAL REVENUE | 0.00 | 0.00 | 0.00 | 0.00 | 0.00 | 0.00 | 0.00 |
| UTILITY REVENUE | 2,295,000.00 | 202,697.16 | 0.00 | 1,794,436.87 | 0.00 | 500,563.13 | 78.19 |
| OTHER REVENUE | 0.00 | 0.00 | 0.00 | 43,747.64 | 0.00 | (43,747.64) | 0.00 |
| INVESTMENT REVENUE | <u>20,000.00</u> | <u>2,919.00</u> | <u>0.00</u> | <u>14,644.00</u> | <u>0.00</u> | <u>5,356.00</u> | <u>73.22</u> |
| *** TOTAL REVENUES *** | <u>2,315,000.00</u> | <u>205,616.16</u> | <u>0.00</u> | <u>1,852,828.51</u> | <u>0.00</u> | <u>462,171.49</u> | <u>80.04</u> |
| <u>EXPENDITURE SUMMARY</u> | | | | | | | |
| ADMINISTRATION | 1,643,571.00 | 1,662.35 | 0.00 | 860,421.68 | 0.00 | 783,149.32 | 52.35 |
| WATER PRODUCTION | 971,049.00 | 59,300.58 | 8,311.44 | 532,819.15 | 22,407.79 | 424,133.50 | 56.32 |
| WATER DISTRIBUTION | <u>299,757.00</u> | <u>23,774.45</u> | <u>8,370.59</u> | <u>210,639.32</u> | <u>0.00</u> | <u>97,488.27</u> | <u>67.48</u> |
| *** TOTAL EXPENDITURES *** | <u>2,914,377.00</u> | <u>84,737.38</u> | <u>16,682.03</u> | <u>1,603,880.15</u> | <u>22,407.79</u> | <u>1,304,771.09</u> | <u>55.23</u> |
| ** REVENUE OVER (UNDER) EXPENDITURES * | <u>(599,377.00)</u> | <u>120,878.78</u> | <u>16,682.03</u> | <u>248,948.36</u> | <u>(22,407.79)</u> | <u>(842,599.60)</u> | <u>140.58</u> |

REVENUE & EXPENSE REPORT

AS OF:AUGUST 31ST, 2020

39 -SANITATION/RECYCLING FUND

FINANCIAL SUMMARY

| | CURRENT BUDGET | CURRENT PERIOD | PRIOR YEAR PO ADJUST. | Y-T-D ACTUAL | Y-T-D ENCUMBRANCE | BUDGET BALANCE | % OF BUDGET |
|---|-------------------|-------------------|--------------------------|-------------------|----------------------|----------------------|----------------|
| <u>REVENUE SUMMARY</u> | | | | | | | |
| BUDGETED CASH CARRYOVER | 0.00 | 0.00 | 0.00 | 0.00 | 0.00 | 0.00 | 0.00 |
| UTILITY REVENUE | 580,900.00 | 48,821.90 | 0.00 | 427,327.87 | 0.00 | 153,572.13 | 73.56 |
| OTHER REVENUE | 0.00 | 0.00 | 0.00 | 0.00 | 0.00 | 0.00 | 0.00 |
| INVESTMENT REVENUE | <u>3,000.00</u> | <u>576.00</u> | <u>0.00</u> | <u>2,538.00</u> | <u>0.00</u> | <u>462.00</u> | <u>84.60</u> |
| *** TOTAL REVENUES *** | <u>583,900.00</u> | <u>49,397.90</u> | <u>0.00</u> | <u>429,865.87</u> | <u>0.00</u> | <u>154,034.13</u> | <u>73.62</u> |
| <u>EXPENDITURE SUMMARY</u> | | | | | | | |
| ADMINISTRATION | 318,320.00 | 526.64 | 0.00 | 112,628.98 | 0.00 | 205,691.02 | 35.38 |
| SANITATION DEPARTMENT | <u>335,649.00</u> | <u>23,035.87</u> | <u>70.00</u> | <u>178,074.44</u> | <u>0.00</u> | <u>157,644.56</u> | <u>53.03</u> |
| *** TOTAL EXPENDITURES *** | <u>653,969.00</u> | <u>23,562.51</u> | <u>70.00</u> | <u>290,703.42</u> | <u>0.00</u> | <u>363,335.58</u> | <u>44.44</u> |
| ** REVENUE OVER (UNDER) EXPENDITURES *(| <u>70,069.00)</u> | <u>25,835.39</u> | <u>70.00</u> | <u>139,162.45</u> | <u>0.00</u> | <u>(209,301.45)</u> | <u>298.71</u> |

REVENUE & EXPENSE REPORT

AS OF: AUGUST 31ST, 2020

46 -WASTEWATER FUND
FINANCIAL SUMMARY

| | CURRENT BUDGET | CURRENT PERIOD | PRIOR YEAR PO ADJUST. | Y-T-D ACTUAL | Y-T-D ENCUMBRANCE | BUDGET BALANCE | % OF BUDGET |
|--|----------------------|-------------------|--------------------------|-------------------|----------------------|----------------------|----------------|
| <u>REVENUE SUMMARY</u> | | | | | | | |
| BUDGETED CASH CARRYOVER | 0.00 | 0.00 | 0.00 | 0.00 | 0.00 | 0.00 | 0.00 |
| UTILITY REVENUE | 754,400.00 | 68,222.28 | 0.00 | 621,990.93 | 0.00 | 132,409.07 | 82.45 |
| OTHER REVENUE | 0.00 | 0.00 | 0.00 | 0.00 | 0.00 | 0.00 | 0.00 |
| INVESTMENT REVENUE | <u>6,700.00</u> | <u>1,049.00</u> | <u>0.00</u> | <u>4,304.00</u> | <u>0.00</u> | <u>2,396.00</u> | <u>64.24</u> |
| *** TOTAL REVENUES *** | <u>761,100.00</u> | <u>69,271.28</u> | <u>0.00</u> | <u>626,294.93</u> | <u>0.00</u> | <u>134,805.07</u> | <u>82.29</u> |
| <u>EXPENDITURE SUMMARY</u> | | | | | | | |
| ADMINISTRATION | <u>912,134.00</u> | <u>13,802.40</u> | <u>1,668.24</u> | <u>283,451.61</u> | <u>1,583.01</u> | <u>628,767.62</u> | <u>31.07</u> |
| *** TOTAL EXPENDITURES *** | <u>912,134.00</u> | <u>13,802.40</u> | <u>1,668.24</u> | <u>283,451.61</u> | <u>1,583.01</u> | <u>628,767.62</u> | <u>31.07</u> |
| ** REVENUE OVER (UNDER) EXPENDITURES * | <u>(151,034.00)</u> | <u>55,468.88</u> | <u>1,668.24</u> | <u>342,843.32</u> | <u>(1,583.01)</u> | <u>(493,962.55)</u> | <u>327.05</u> |

2019

| Year | Month | 10.300.2120 | | 10.401.9016 | | 10.401.9051 | | 10.401.9052 | | PROJECTED BUDGET TOTAL \$400,000 |
|-------|-------|----------------|-------------|------------------------|--------------|-------------------|---------------------|--------------|------------|----------------------------------|
| | | Total Received | General 50% | Industrial Econ Dev 7% | Cap Impr 25% | Equip Reserve 18% | Over/(Under) Budget | TOTAL | | |
| JAN | Dec | 51,663.16 | 25,831.58 | 3,616.42 | 12,915.79 | 9,299.37 | \$23,355.70 | 28,307.46 | 51,663.16 | 8.74% |
| FEB | Jan | 45,055.02 | 22,527.51 | 3,153.85 | 11,263.76 | 8,109.90 | \$23,284.49 | 21,770.53 | 96,718.18 | 16.39% |
| MAR | Feb | 53,741.41 | 26,870.71 | 3,761.90 | 13,435.35 | 9,673.45 | \$22,218.43 | 31,522.98 | 150,459.59 | 23.97% |
| APR | Mar | 45,770.93 | 22,885.47 | 3,203.97 | 11,442.73 | 8,238.77 | \$23,313.48 | 22,457.45 | 196,230.52 | 31.65% |
| MAY | Apr | 44,366.58 | 22,183.29 | 3,105.66 | 11,091.65 | 7,985.98 | \$25,167.54 | 19,199.04 | 240,597.10 | 39.39% |
| JUN | May | 55,633.46 | 27,816.73 | 3,894.34 | 13,908.37 | 10,014.02 | \$25,550.85 | 30,082.61 | 296,230.56 | 47.23% |
| JUL | Jun | 39,519.42 | 19,759.71 | 2,766.36 | 9,879.86 | 7,113.50 | \$25,056.36 | 14,463.06 | 335,749.98 | 64.35% |
| AUG | Jul | 32,067.19 | 16,033.60 | 2,244.70 | 8,016.80 | 5,772.09 | \$24,895.14 | 7,172.05 | 367,817.17 | 72.68% |
| SEP | Aug | 41,036.31 | 20,518.16 | 2,872.54 | 10,259.08 | 7,386.54 | \$26,617.29 | 14,419.02 | 408,853.48 | 81.89% |
| OCT | Sep | 32,315.84 | 16,157.92 | 2,262.11 | 8,078.96 | 5,816.85 | \$14,999.58 | 17,316.26 | 441,169.32 | 91.25% |
| NOV | Oct | 37,519.22 | 18,759.61 | 2,626.35 | 9,379.81 | 6,753.46 | \$156,060.81 | (118,541.59) | 478,688.54 | 100.00% |
| DEC | Nov | 36,695.90 | 18,347.95 | 2,588.71 | 9,173.98 | 6,605.26 | \$0.00 | 36,695.90 | 515,384.44 | |
| Total | | 515,384.44 | 257,692.22 | 36,076.91 | 128,846.11 | 92,769.20 | \$390,519.67 | 124,864.77 | | |

| Year | Amount | % Change |
|------|------------|----------|
| 2018 | 436,151.56 | 9.11% |
| 2017 | 399,732.55 | 0.59% |
| 2016 | 397,383.34 | -11.51% |
| 2015 | 449,066.85 | -8.93% |
| 2014 | 493,114.38 | 10.75% |
| 2013 | 445,245.43 | -2.82% |
| 2012 | 458,145.25 | -1.79% |
| 2011 | 466,481.58 | 15.27% |
| 2010 | 404,676.03 | |

2020

| Year | Month | 10.300.2120 | | 10.401.9016 | | 10.401.9051 | | 10.401.9052 | | PROJECTED BUDGET TOTAL \$530,000 |
|-------|-------|----------------|-------------|------------------------|--------------|-------------------|---------------------|--------------|------------|----------------------------------|
| | | Total Received | General 50% | Industrial Econ Dev 7% | Cap Impr 25% | Equip Reserve 18% | Over/(Under) Budget | TOTAL | | |
| JAN | Dec | 39,811.86 | 19,905.93 | 2,786.83 | 9,952.97 | 7,166.13 | \$29,526.73 | 10,285.13 | 39,811.86 | 9.47% |
| FEB | Jan | 37,228.85 | 18,614.43 | 2,606.02 | 9,307.21 | 6,701.19 | \$27,401.13 | 9,827.72 | 77,040.71 | 17.71% |
| MAR | Feb | 34,794.01 | 17,397.01 | 2,435.58 | 8,698.50 | 6,262.92 | \$31,255.81 | 3,538.20 | 111,834.72 | 26.85% |
| APR | Mar | 31,516.70 | 15,758.35 | 2,206.17 | 7,879.18 | 5,673.01 | \$29,239.47 | 2,277.23 | 143,351.42 | 34.99% |
| MAY | Apr | 31,225.15 | 15,612.58 | 2,185.76 | 7,806.29 | 5,620.53 | \$28,588.93 | 2,636.22 | 174,576.57 | 43.04% |
| JUN | May | 33,946.38 | 16,973.19 | 2,376.25 | 8,486.60 | 6,110.35 | \$31,860.90 | 2,085.48 | 208,522.95 | 52.51% |
| JUL | Jun | 28,808.84 | 14,404.42 | 2,016.62 | 7,202.21 | 5,185.59 | \$29,096.10 | (287.26) | 237,331.79 | 60.52% |
| AUG | Jul | 35,085.00 | 17,542.50 | 2,455.95 | 8,771.25 | 6,315.30 | \$26,364.88 | 8,720.12 | 272,416.79 | 67.70% |
| SEP | Aug | | | | | | \$28,931.21 | (28,931.21) | 272,416.79 | 75.62% |
| OCT | Sep | | | | | | \$11,453.42 | (11,453.42) | 272,416.79 | 83.49% |
| NOV | Oct | | | | | | \$167,879.03 | (167,879.03) | 272,416.79 | 91.88% |
| DEC | Nov | | | | | | \$13,005.81 | (13,005.81) | 272,416.79 | 100.00% |
| Total | | 272,416.79 | 136,208.40 | 19,069.18 | 68,104.20 | 49,035.02 | \$454,603.42 | (182,186.63) | | |

| Year | Amount | % Change |
|------|------------|----------|
| 2019 | 515,384.44 | 18.17% |
| 2018 | 436,151.56 | 9.11% |
| 2017 | 399,732.55 | 0.59% |
| 2016 | 397,383.34 | -11.51% |
| 2015 | 449,066.85 | -8.93% |
| 2014 | 493,114.38 | 10.75% |
| 2013 | 445,245.43 | -2.82% |
| 2012 | 458,145.25 | -1.79% |
| 2011 | 466,481.58 | 15.27% |
| 2010 | 404,676.03 | |



City Council Agenda Form

Meeting Date: September 15, 2020
Agenda Item Title: Unit #10 Base Alignment
Department: Electric

Agenda Item Description: Frame Realignment and Chocking

Background: Unit 10 Web deflections indicated potential crank shaft bowing. Exline was contacted and additional tests and measurements were performed. It was recommended to bring in Iron Horse Energy Services for Laser measuring of the engine base and crank shaft. Iron Horse was able to identify that the engine base was out of alignment and would need to be re-chocked. Iron Horse has provided two options:

#1. Chip out 4-5 blocks, align and repour. Option 1 is estimated at \$47,711.

#2. Grind overpour from the chocks, raise, align and add shims. Option 2 is estimated at \$27,711

In addition to both options, Exline would provide one mechanic to work with Iron Horse to provide the mechanical work needed for the realignment. Exline provided a quote for \$3,929.

City Attorney Review/ Comment: NA

Funding Source: Electric Depreciation Fund

Options:

1. Authorize the Electric Department to proceed with accepting the proposal from Iron Horse and Exline to realign the bed plate of unit 10
2. Provide alternative direction to the Electric Department
3. Take no action - repairs are not commenced

Staff Recommendation: Approve the Estimate from Iron Horse and Exline under Option #1, Chipping out blocks, realign and repour chock blocks (Estimate of \$47,711 for Iron Horse and \$3,929 from Exline), to be paid from the Electric Depreciation Fund.

Attachment(s): Test results, quotes and estimate



An Experienced Value-Added Approach

**Iron Horse Energy Services, Inc.
419 W Outer Rd
Eolia, MO 63344**

Exline Quotation #: 20-040087-1

Date: 08-13-2020

Attn: Johnson, Randy

Thank you for the opportunity to present this proposal. Exline, Inc. has been in the Industrial Repair, Service and Manufacturing business for over 140 years providing a full range of products and services to natural gas transmission, petrochemical, power utilities, marine, plastics and industrial customers. Exline features a reliable staff who specialize in your repair and manufacturing needs.

Exline welcomes the opportunity to meet and discuss the details of our proposal prior to order placement and we look forward to working with you.

Sincerely,

Kevin Koochel
Exline, Inc.
3256 East Country Club Road
PO Box 1487
Salina, KS 67402-1487
Phone: 800.255.0111 * 785.825.4683
Mobile: 785.643.0249
Fax: 785.826.4425
Email: k.koochel@exline-inc.com

'It's time to put our experience to work for you'



PO BOX 1487 * 3256 E. COUNTRY CLUB ROAD
 SALINA, KANSAS 67402-1487
 800-255-0111 * 785-825-4683 * FAX 785-826-4425

Iron Horse Energy Services, Inc.
Attn: Johnson, Randy
419 W Outer Rd
Eolia, MO 63344

PRICE QUOTATION 20-040087-1

PLEASE INDICATE THIS
NUMBER WHEN ORDERING

| | |
|---|--------------------------|
| DATE 08-13-2020 | |
| YOUR INQUIRY DATED | |
| AVAILABILITY | |
| TERMS Net 30 | FOB Salina, KS |
| CUSTOMER REPRESENTATIVE Kevin Koochel | |

| Item | Quantity | Description | Unit Price | Amount |
|------|----------|--|------------|----------|
| 1 | 1 | <p>Labor, expenses, and travel for 1 Exline mechanic working ten hour days for four days to assist with taking webs and mechanical work associated with the frame alignment and chock work on one Nordberg TS 21 generation unit located at the City of Russell, KS power plant.</p> <p>Freight, Handling and Sales/Use Taxes are not included in the price quotation. Additional charges, if any, will be added to the invoice upon completion of work.</p> <p>Warranty: Refer to Exline, Inc. Product and Service Warranty statement for details. A copy can be obtained at www.exline-inc.com/warranty.</p> <p>This quotation is valid for: 30 days</p> <p>Price and delivery are based on costs and conditions existing on the date of quotation and are subject to change. Typographical and stenographic errors are subject to correction. Buyer assumes liability for patent and copyright infringements when goods are made to Buyer's specifications. Conditions specifically stated herein shall be governed by established trade customs. Unless a previously, mutually executed agreement exists, terms inconsistent with those stated herein which may appear on Buyer's formal order will not be binding on the Seller</p> <p>Acceptance of the offer being made under this quotation is expressly limited to Buyer's acceptance of all the terms and conditions of this offer, including, without limitation, Exlines standard Product and Service Warranty statement. Exline hereby objects to any additional, contradictory or different terms contained in any subsequent order or communication from Buyer pertaining to the goods or services described herein. http://www.exline-inc.com/terms-conditions</p> | 3,929.00 | 3,929.00 |

Signed

| | | |
|--------|---------------|-------------|
| P.O. # | Date Accepted | Approved By |
|--------|---------------|-------------|

Iron Horse Energy Services, Inc.

419 W. Outer Road
Eolia, MO 63344
573-485-8000
573-485-8006 (Fax)

Optical Profile

Job # 927T

City of Russell
Russell, KS

Nordbert TS2110 Unit 10

As found - Shot off machined AB area

J. Leake 05-22-2020 mw

◆ Left Side

■ Right Side

Inches

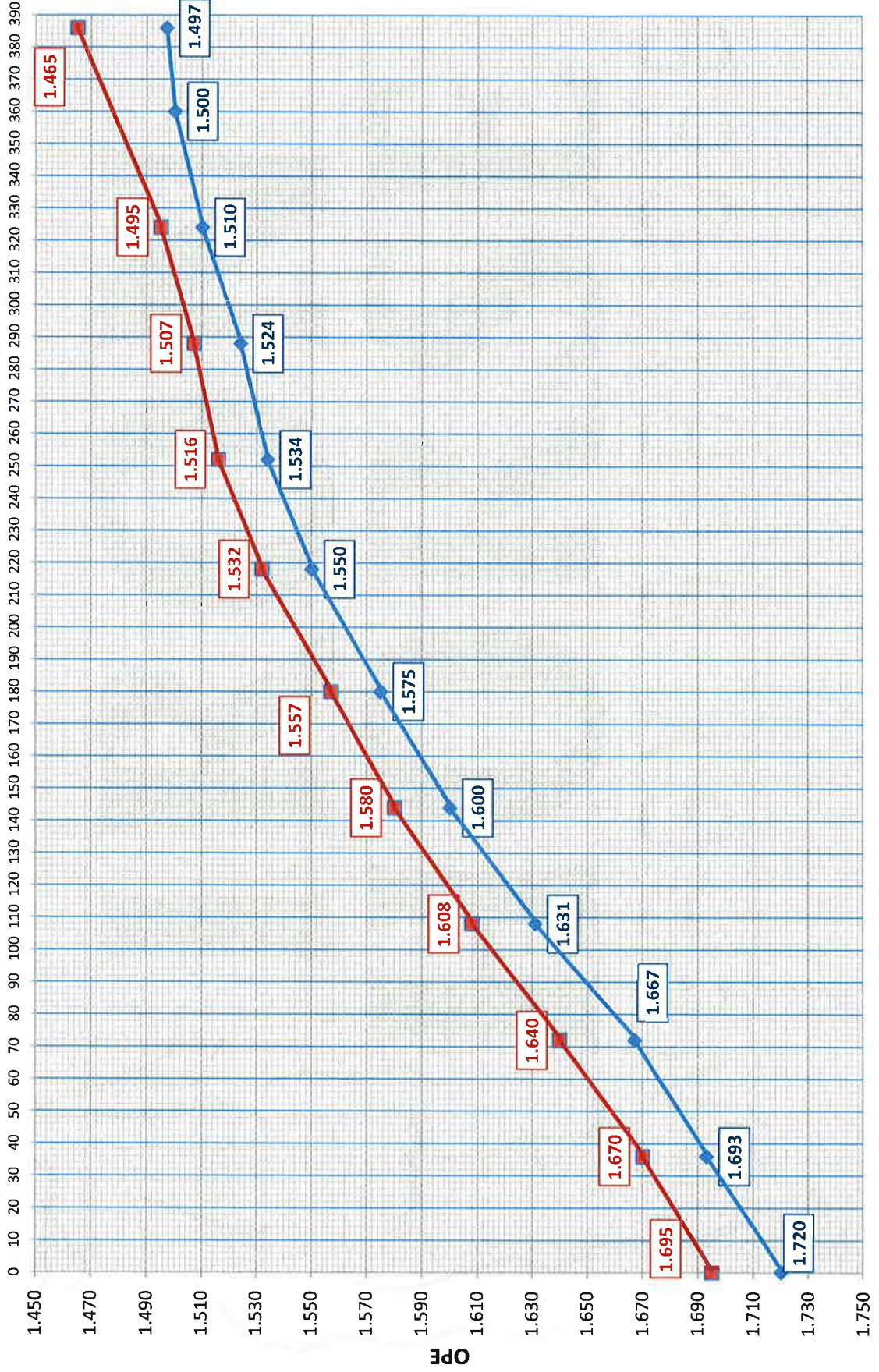

CUSTOMER DAVE
 ORDER NO. 10
 READINGS TAKEN BY DAVE
 ENGINE TYPE TS
 DATE 28 APR 2020

COUNTER CLOCKWISE
 ROTATION

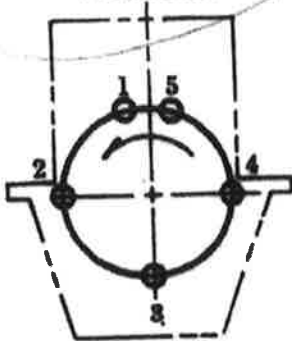

CLOCKWISE
 ROTATION

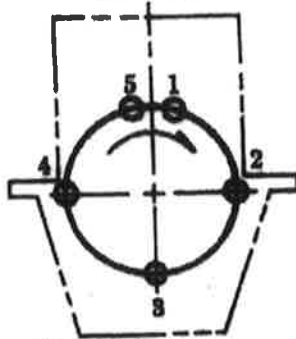

STRAIN GAUGE POSITIONS

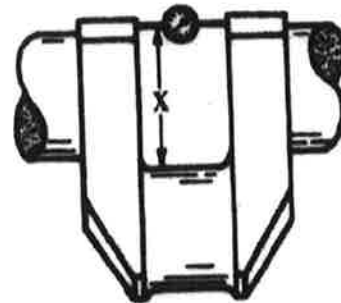

STRAIN GAUGE IN POSITION WITH
 CRANK NEAR BOTTOM CENTER FOR
 FIRST READING

ROTATION WHEN FACING POWER
 END FLANGE IS:

COUNTER CLOCKWISE
 CLOCKWISE

DISTANCE & STRAIN GAUGE FROM
 CRANKPIN:
 DIMENSION 'X' = _____ INCHES

ENG. HOT ENG. COLD

| CRANK NUMBER | STRAIN GAUGE POSITION | | | | | REMARKS |
|-----------------|-----------------------|------|------|------|------|---------|
| | 1 | 2 | 3 | 4 | 5 | |
| 1 | 0 | +1/2 | +1 | +1 | 0 | |
| 2 | 0 | +1 | +1 | +1 | 0 | |
| 3 | 0 | 0 | -0.5 | 0 | +1/2 | |
| 4 | 0 | -1/2 | -2.5 | -1 | +1/2 | |
| 5 | 0 | -2 | -3.5 | -1 | 0 | |
| 6 | 0 | -2 | -4.5 | -2 | 0 | |
| 7 | 0 | -1.5 | -4 | -2.5 | 0 | |
| 8 | 0 | -1 | -3 | -1 | 0 | |
| 9 | 0 | -1 | -2 | -2 | -1 | |
| 10 | 0 | -1 | -5 | -4 | -2 | |
| 11 | | | | | | |
| 12 | | | | | | |

IRON HORSE ENERGY SERVICES

DATA SHEET

| | | | | | |
|---------------------------|---------------------------|-----------------------------|--------------|-------------|---------------|
| COMPANY | LOCATION | ENGINE MFG. | ENGINE TYPE: | LAST REPORT | HRS. OPERATED |
| City of Russell | Russell KS | Nordberg | 752110 | #10 | 5-22-20 |
| IRON HORSE REPRESENTATIVE | ANCHOR BOLT TORQUE VALUES | WORK ORDER NO. - JOB NUMBER | | | |
| John Lake | Luis Barraza | 927 | | | |

CRANKSHAFT WEB DEFLECTIONS HOT WARM COLD READ TO THE NEAREST 1/4 THOUSANDTH OF AN INCH

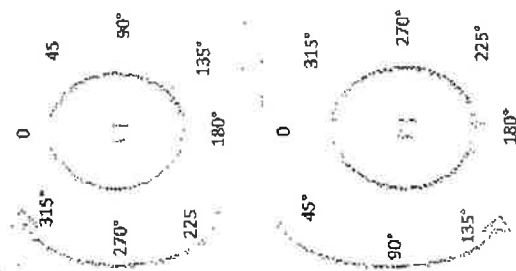

CRANK POSITION FACING FLYWHEEL
(please check the one that applies)

| CIRCLE | 1 | | 2 | | 3 | | 4 | | 5 | | 6 | | 7 | | 8 | | 9 | | 10 | |
|--------|----------|----------|----------|----------|----------|----------|----------|----------|----------|----------|----------|----------|----------|----------|----------|----------|----------|----------|----------|--|
| | PWR/COMP | PWR/COMP | PWR/COMP | PWR/COMP | PWR/COMP | PWR/COMP | PWR/COMP | PWR/COMP | PWR/COMP | PWR/COMP | PWR/COMP | PWR/COMP | PWR/COMP | PWR/COMP | PWR/COMP | PWR/COMP | PWR/COMP | PWR/COMP | PWR/COMP | |
| THROW | 1 | 2 | 3 | 4 | 5 | 6 | 7 | 8 | 9 | 10 | | | | | | | | | | |
| 0 | | | | | | | | | | | | | | | | | | | | |
| 45 | | | | | | | | | | | | | | | | | | | | |
| 90 | | | | | | | | | | | | | | | | | | | | |
| 135 | | | | | | | | | | | | | | | | | | | | |
| 180 | | | | | | | | | | | | | | | | | | | | |
| 225 | | | | | | | | | | | | | | | | | | | | |
| 270 | | | | | | | | | | | | | | | | | | | | |
| 315 | | | | | | | | | | | | | | | | | | | | |

| BENCHMARK & LOCATION | 1 | | 2 | | 3 | | 4 | | 5 | | 6 | | 7 | | 8 | | 9 | | 10 | | 11 | | 12 | |
|--|------------------|-------|------------------|-------|------------------|-------|------------------|-------|------------------|-------|------------------|-------|------------------|------|------------------|------|------------------|------|------------------|------|------------------|------|------------------|------|
| | Optical Readings | Span | Optical Readings | Span | Optical Readings | Span | Optical Readings | Span | Optical Readings | Span | Optical Readings | Span | Optical Readings | Span | Optical Readings | Span | Optical Readings | Span | Optical Readings | Span | Optical Readings | Span | Optical Readings | Span |
| B.M. 1.000 | 0 | 36 | 72 | 108 | 144 | 180 | 218 | 252 | 288 | 324 | 360 | 386 | | | | | | | | | | | | |
| PEG TEST | 1.720 | 1.693 | 1.667 | 1.631 | 1.600 | 1.575 | 1.550 | 1.534 | 1.524 | 1.510 | 1.500 | 1.497 | | | | | | | | | | | | |
| Compressor Rod Run Out & Slide Elevation | 1.695 | 1.670 | 1.640 | 1.608 | 1.580 | 1.557 | 1.532 | 1.516 | 1.507 | 1.495 | 1.480 | 1.465 | | | | | | | | | | | | |

NOTE: RUN OUT TO BE STARTED WITH PISTON FULL IN BORAD. 1 DIAL INDICATOR ON TOP OF ROD AND 1 INDICATOR ON FW SIDE OF ROD.

Shot off machined Anchor Bolt Area
 Fax 573-485-8006
 tmarose@russellcity.org

Duane Banks

From: Randy Johnson <rjohnson@ironhorseinc.net>
Sent: Saturday, August 22, 2020 8:28 AM
To: Terry Morse
Cc: John Luder; John Leake; Mary Winkle
Subject: RE: City of Russell, KS Readings
Attachments: Exline-City of Russell KS.pdf

Terry,

If we would chip out 4-5 chocks back from the FEW align and repour they would be looking at a cost around \$47,711.00 4 men 7 days. If we grind the over pour off the chocks raise/align and try to put shims on top of the epoxy chock cost around \$27,711.00 4 men 4 days. Exline could send 1 tech to assist on setting of air gap their pricing is attached please call me after you review.

Thanks,

Randy Johnson
Iron Horse Energy Services
419 W. Outer Road
Eolia, MO 63344
573-485-8000 Office
573-470-7631 Cell

This electronic transmission (and any attached document or file) is confidential and intended for the sole use of the individual (s) to whom it is addressed. Any further distribution or copying of this message is strictly prohibited. If you received this message in error, please notify the sender and destroy the message (and attached files) immediately. Iron Horse Energy Inc. is not liable for any use or misuse contrary to these directions.

From: Mary Winkle <mwinkle@ironhorseinc.net>
Sent: Friday, May 22, 2020 1:12 PM
To: tmorse@russellcity.org
Cc: Randy Johnson <rjohnson@ironhorseinc.net>; John Leake <jleake@ironhorseinc.net>
Subject: City of Russell, KS Readings

Attached please find the readings for unit 10, please call John Leake at 573-470-8013.

Thank you,

Mary Winkle

Iron Horse Energy Services, Inc.
419 W. Outer Road
Eolia, MO 63344
573-485-8000
573-485-8006 Fax

This electronic transmission (and any attached document or file) is confidential and intended for the sole use of the individual (s) to whom it is addressed. Any further distribution or copying of this message is strictly prohibited. If you received this message in error, please notify the sender and destroy the message (and attached files) immediately. Iron Horse Energy Inc. is not liable for any use or misuse contrary to these directions.



City Council Agenda Form

Meeting Date: September 15, 2020
Agenda Item Title: CDBG St. John Water Line Project Draw Down #3
Department: City Clerk

Agenda Item Description: CDBG St. John Water Line Project Draw Down #3

Background: The City received a \$600,000 CDBG Grant for the St. John Water Line Project. Northwest Kansas Planning & Development Commission is the grant administrator. Staff is asking the council to approve the 3rd CDBG draw down in the amount of \$69,000.00 for reimbursement of the grants share of expenses.

City Attorney Review/ Comment: N/A

Funding Source: N/A

Options:

1. Approve the CDBG St. John water line project Draw Down #3 in the amount of \$69,000.
2. Pass on the draw down.

Staff Recommendation: Approve the CDBG St. John water line project Draw Down #3 in the amount of \$69,000.

Attachment(s): CDBG Request for Payment

REQUEST FOR PAYMENT OF CDBG FUNDS

CFDA 14.228

PART I: REQUEST FOR PAYMENT INFORMATION

GRANTEE - NAME City of Russell

GRANT NO. 19-PF-018

STREET ADDRESS 133 W. 8th Street

REQUEST NO. 3

PO BOX 112

treasurer@russellcity.org

CITY, STATE, ZIP Russell, KS 67665

Grantee's - E-mail address for notifying about ACH deposit

nwkpdc@ruraltel.net

Administrator - E-mail address for notifying about ACH deposit

PART II: STATUS OF CDBG FUNDS

| | AMOUNT |
|--|------------|
| 1 PAYMENT DUE & AMOUNT OF THIS REQUEST | 69,000.00 |
| 2 CDBG GRANT AWARD | 600,000.00 |
| 3 PROGRAM INCOME AND OTHER RECEIPTS | . |
| 4 TOTAL FUNDS (2 + 3) | 600,000.00 |
| 5 CDBG FUNDS RECEIVED TO DATE | 100,700.00 |
| 6 TOTAL (1 + 5) | 169,700.00 |
| 7 REMAINING CDBG FUNDS (4 - 6) | 430,300.00 |

PART III: CERTIFICATION

I HEREBY CERTIFY THAT THE DATA REPORTED ABOVE IS CORRECT AND THAT THE AMOUNT REQUESTED IS NOT IN EXCESS OF CURRENT NEEDS

DATE 9/15/2020 SIGNATURE TITLE

DATE 9/15/2020 SIGNATURE TITLE

PART IV: APPROVAL (FOR KANSAS DEPT. OF COMMERCE USE ONLY)

CDBG APPROVAL:

- 1. CONTRACT TERMINATION DATE: _____
- 2. AUTHORIZED SIGNATURE: _____
- 3. MONITORING RESOLUTION: CURRENT / PAST DUE / NA
- 4. QUARTERLY PROGRESS REPORTS: CURRENT / PAST DUE

FIELD REPRESENTATIVE _____ DATE _____

ECONOMIC DEVELOPMENT SPECIALIST _____ DATE _____

ADMINISTRATIVE/ COMPLIANCE _____ DATE _____

FISCAL _____ DATE _____

Bartlett & West

Driving Community and Industry Forward, Together.

Invoice Remittance Address
For Payments Only:
P.O. Box 663
Wichita, KS 67201-0663

230 Poyntz Avenue
Manhattan, KS 66502
785.537.8467 FAX 785.537.3274 877.508.2252
F.E.I.N. 48-0770612

Richard Krause
City of Russell
133 W 8th
Russell, KS 67665

August 10, 2020
Project No: 016251.022
Invoice No: 730076941
No No 19-0329 #01
Project Manager: Nathan Bergman

Project 016251.022 Russell: Maple-St. John Waterline Construction Phase Services *RK-8/12/2020*

Professional Services from June 27, 2020 to July 24, 2020

Phase 70 Construction Administration
Task 700 Construction Administration

Professional Services

| | Hours | Rate | Amount |
|---------------------------|-------|--------|-----------------|
| Engineer X | | | |
| Engineer X | 7.50 | 210.00 | 1,575.00 |
| Engineer VII | | | |
| Engineer VII | 13.00 | 170.00 | 2,210.00 |
| Engineer I | | | |
| Engineer I | 7.10 | 102.00 | 724.20 |
| Engineering Tech I | | | |
| Engineering Tech I | 11.00 | 63.00 | 693.00 |
| Construction Eng Tech III | | | |
| Construction Eng Tech III | 5.00 | 90.00 | 450.00 |
| Administrator III | | | |
| Administrator III | 2.30 | 87.00 | 200.10 |
| Administrative Tech II | | | |
| Administrative Tech II | .25 | 53.00 | 13.25 |
| Totals | 46.15 | | 5,865.55 |
| Total Labor | | | 5,865.55 |

Reimbursable Expenses

| | | | |
|----------------------------|--|--|---------------|
| Mileage | | | 258.75 |
| Total Reimbursables | | | 258.75 |

Total this Task \$6,124.30

Total this Phase \$6,124.30

Phase 71 Construction Observation
Task 710 Construction Observation

Professional Services

| | Hours | Rate | Amount |
|--------------------------|-------|--------|--------|
| Construction Eng Tech IX | | | |
| Construction Eng Tech IX | 2.00 | 160.00 | 320.00 |

We appreciate your business. Please include invoice no. on check.

| Project | 016251.022 | Maple-St. John Waterline CPS | | Invoice | 730076941 |
|----------------------------------|------------|------------------------------|---------------------------|-------------------------|--------------------|
| Construction Eng Tech III | | | | | |
| Construction Eng Tech III | | | 96.00 | 90.00 | 8,640.00 |
| Construction Eng Tech III | | Ovt | 21.50 | 121.50 | 2,612.25 |
| Totals | | | 119.50 | | 11,572.25 |
| Total Labor | | | | | 11,572.25 |
| Reimbursable Expenses | | | | | |
| Meals | | | | | 247.50 |
| Travel Expenses | | | | | 768.00 |
| Per Diem | | | | | 247.50 |
| Total Reimbursables | | | | | 1,263.00 |
| Unit Billing | | | | | |
| Company Vehicle Mileage | | | | | 506.00 |
| Total Units | | | | | 506.00 |
| | | | | Total this Task | \$13,341.25 |
| | | | | Total this Phase | \$13,341.25 |
| Billing Limits | | | | | |
| | | Current | Prior | To-Date | |
| Total Billings | | 19,465.55 | 0.00 | 19,465.55 | |
| Limit | | | | 36,000.00 | |
| Remaining | | | | 16,534.45 | |
| | | | Total this Invoice | | \$19,465.55 |



Contractor's Application for Payment No. Two (2)

Application: 07/23/2020 to 08/24/2020 Application Date: 8/25/2020
 Period: From (Contractor): APAC-Kansas, Inc., Streets Division Via (Engineer): Bartlett & West
 Contract: Contractor's Project No.: 680717 Engineer's Project No.: 16251.021
 To (Owner): City of Russell, Kansas
 Project: Waterline Improvements
 Owner's Contract No.: 16251.021

**Application For Payment
Change Order Summary**

| Approved Change Order Number | Additions | Deductions |
|---|-----------|-------------|
| 1. ORIGINAL CONTRACT PRICE \$ 1,057,188.00 | | |
| 2. Net change by Change Orders \$ | | |
| 3. Current Contract Price (Line 1 + 2) \$ 1,057,188.00 | | |
| 4. TOTAL COMPLETED AND STORED TO DATE (Column F total on Progress Exhaust) | | |
| 5. RETAINAGE: | | |
| a. 10% X \$171,890.33 Work Completed | \$ | \$17,189.03 |
| b. 10% X \$213,220.55 Stored Materials | \$ | \$21,322.06 |
| c. Total Retenages (Line 5a + Line 5b) | \$ | \$38,511.11 |
| 6. AMOUNT ELIGIBLE TO DATE (Line 4 - Line 5c) | | |
| 7. LESS PREVIOUS PAYMENTS (Line 6 from prior Application) | | |
| 8. AMOUNT DUE THIS APPLICATION | | |
| 9. BALANCE TO FINISH, PLUS RETAINAGE (Column G total on Progress Estimator + Line 5c above) | | |
| \$ 1,449,912.55 | | |

Contractor's Certification
 The undersigned Contractor certifies, to the best of his knowledge, the following:
 (1) All previous progress payments received from Owner on account of Work done under the Contract have been applied on account to discharge Contractor's legitimate obligations incurred in connection with the Work covered by prior Applications for Payment.
 (2) Title to all Work, materials and equipment incorporated in said Work, or otherwise listed in or covered by this Application for Payment, will pass to Owner at time of payment free and clear of all Liens, security interests, and encumbrances (except such as are covered by a bond acceptable to Owner indemnifying Owner against any such Liens, security interest, or encumbrances); and
 (3) All the Work covered by this Application for Payment is in accordance with the Contract Documents and is not defective.

Contractor Signature: *[Signature]* Date: 8/25/2020

Payment of: \$ 1,449,912.55 (Line 8 or other - attach explanation of the other amount) 8-26-20 (Date)
 is recommended by: *[Signature]* (Engineer)
 Payment of: \$ 149,912.55 (Line 8 or other - attach explanation of the other amount)
 is approved by: *[Signature]* (Owner) 8/27/2020 (Date)
 Approved by: _____ Funding or Financing Entity (if applicable) _____ (Date)

| Bid Item | Description | Plan Quantity | Unit | Unit Price | Quantity Previous | Quantity This Period | Total Quantity | Cost This Period | Total Cost |
|-------------------------------|---|---------------|------|-------------|-------------------|----------------------|----------------|------------------|--------------|
| 22 | Reconnect 1" Service Line | 3.00 | EA | \$715.00 | 0.00 | 0.00 | 0.00 | \$0.00 | \$0.00 |
| 23 | Landscaping and Seeding | 1.00 | LS | \$55,666.00 | 0.00 | 0.00 | 0.00 | \$0.00 | \$0.00 |
| 24 | Bid Alt. No. 1 to include items in red on sheet 4 | 1.00 | LS | \$8,319.00 | 0.00 | 0.00 | 0.00 | \$0.00 | \$0.00 |
| 501 | 8" C900 PVC Pipe (Stored Materials) | 9680.00 | LF | \$7.43 | 9680.00 | 0.00 | 9680.00 | \$0.00 | \$71,922.40 |
| 502 | 6" C900 PVC Pipe (Stored Materials) | 4829.00 | LF | \$3.45 | 4829.00 | 0.00 | 4829.00 | \$0.00 | \$16,660.05 |
| 504 | 8" Gate Valves (Stored Materials) | 30.00 | EA | \$871.60 | 30.00 | 0.00 | 30.00 | \$0.00 | \$26,148.00 |
| 505 | 6" Gate Valves (Stored Materials) | 20.00 | EA | \$565.12 | 20.00 | 0.00 | 20.00 | \$0.00 | \$11,302.40 |
| 506 | Fire Hydrants (Stored Materials) | 26.00 | EA | \$2,009.54 | 26.00 | 0.00 | 26.00 | \$0.00 | \$52,248.04 |
| 507 | 8" Road Crossing (Stored Materials) | 19.00 | EA | \$903.78 | 19.00 | 0.00 | 19.00 | \$0.00 | \$17,171.82 |
| 508 | 6" Road Crossing (Stored Materials) | 9.00 | EA | \$132.18 | 9.00 | 0.00 | 9.00 | \$0.00 | \$1,189.62 |
| 509 | 8" Install By Bore (Stored Materials) | 1197.00 | LF | \$7.77 | 1197.00 | 0.00 | 1197.00 | \$0.00 | \$9,300.69 |
| 510 | 6" Install By Bore (Stored Materials) | 175.00 | LF | \$0.57 | 175.00 | 0.00 | 175.00 | \$0.00 | \$99.75 |
| 518 | Connect to Existing 8" Line (Stored Materials) | 18.00 | EA | \$169.24 | 18.00 | 0.00 | 18.00 | \$0.00 | \$3,046.32 |
| 519 | Connect to Existing 6" Line (Stored Materials) | 4.00 | EA | \$109.04 | 4.00 | 0.00 | 4.00 | \$0.00 | \$436.16 |
| 520 | Connect to Existing 4" Line (Stored Materials) | 17.00 | EA | \$183.63 | 17.00 | 0.00 | 17.00 | \$0.00 | \$3,121.71 |
| 524 | Bid Alternate (Stored Materials) | 1.00 | LS | \$573.59 | 1.00 | 0.00 | 1.00 | \$0.00 | \$573.59 |
| Totals | | | | | | | | | \$385,111.08 |
| Less Retainage | | | | | | | | | 10 % |
| Total Complete Less Retainage | | | | | | | | | \$346,599.97 |
| Less Previous Payments | | | | | | | | | \$196,687.42 |
| Amount Due This Application | | | | | | | | | \$149,912.55 |

* * *

City of Russell, Kansas
Contractors Payment Estimate

Project: Water Well and Waterline Improvements
 Estimate No: Two (2)
 Estimate Period: 05-24-2020

Contractor: APAC-Kansas, Inc., Shears
 Address: P. O. Box 1605
 Hutchinson, KS 67504-1605
 Jobs: 690718

| Bid Item | Quantity | Unit | Bid Item Unit Price | Bid Price Extension | Completed Quantity | Completed Amount | Stored Material | Completed & Stored to Date | Balance to Finish | Percent Complete |
|--------------------|----------|------|---------------------|-----------------------|--------------------|---------------------|-----------------|----------------------------|---------------------|------------------|
| 24 Bid Alt 1 | 1 | LS | \$7,745.41 | \$7,745.41 | | \$0.00 | | \$0.00 | \$7,745.41 | 0.00% |
| STORED MATERIAL | 1 | LS | \$573.59 | \$573.59 | | | 1 | \$573.59 | \$0.00 | 100.00% |
| GRAND TOTAL | | | | \$1,057,186.00 | | \$171,890.53 | | \$385,111.08 | \$672,076.92 | 36.43% |



City Council Agenda Form

Meeting Date: September 15, 2020
Agenda Item Title: General Nuisance Abatement at 1337 N. Elm
Department: Building, Planning, & Zoning

Agenda Item Description: General Nuisance Abatement at 1337 N. Elm

Background: A resolution authorizing the removal of nuisances at 1337 N. Elm. These nuisances include. Trash & Debris, Indoor Furniture, Appliances, Discard items in trailers. The required notification has been provided and the property owner has failed to abate the nuisance(s) or request a hearing before the governing body as required.

Upon approval of the Resolution if the nuisance(s) are not abated in the required time, the city will have the nuisances abated and the property brought into compliance. Costs of the abatement will be charged to the property.

City Attorney Review/ Comment: 9/15/20

Funding Source:

Options:

1. Approve the Resolution authorizing the removal of the nuisance(s) from 1337 N. Elm
2. Provide alternate direction to staff.
3. Take no action - the abatement process is halted.

Staff Recommendation: Approve the Resolution authorizing the removal of the nuisance(s) from 1337 N. Elm and providing the abatement costs, if any, incurred by the city shall be charged against the lots or parcels of ground on which the nuisance is located.

Attachment(s): Required notice, Resolution, Photos

RESOLUTION NO. -20

A RESOLUTION AUTHORIZING THE REMOVAL OF A NUISANCE FROM CERTAIN PROPERTY IN THE CITY OF RUSSELL, KANSAS.

WHEREAS, the Governing Body of the City of Russell has declared it unlawful for any person to maintain a nuisance on private property within the City of Russell; and

WHEREAS, the owners(s) of the private property at the address listed herein have been notified pursuant to Chapter VIII, Article 2, Section 8-207 of the Code of Ordinances of a violation of the Ordinance and have not requested a hearing before the Governing Body;

WHEREAS, the public officer in charge of administration and enforcement of this ordinance has provided the Governing Body with information regarding the condition of the property which is alleged to be a nuisance and after due consideration the Governing Body adopted the following resolution.

NOW, THEREFORE, BE IT RESOLVED BY THE GOVERNING BODY OF THE CITY OF RUSSELL, KANSAS:

Section 1. Upon proper notice and consideration of information provided by the enforcement officer, it was determined that the following condition on the property is a nuisance in violation of Chapter VIII, Article 2, Section 8-201:

1337 N. Elm Beverly Driscoll
Trash & Debris, Indoor Furniture, Appliances, Discard items in trailers

Section 2. Ten (10) days after passage of this resolution the public officer is authorized to enforce the abatement of this condition by abatement of the nuisance if the owner has not previously done so.

Section 3. The abatement costs, if any, incurred by the City shall be charged against the lots or parcels of ground on which the nuisance is located.

Section 4. A copy of this resolution shall be served on the owner of the land as provided in the city's Code of Ordinance.

PASSED AND APPROVED by the Governing Body of the City of Russell, Kansas, on this 15th day of September, 2020.

Raymond C. Mader, Mayor

ATTEST:

Katrina Woelk, City Clerk

10 Day General Nuisance Notice

City of Russell

133 West 8th Street

Russell, KS. 67665

785-483-6311

Case Number: 20200238

CITY OF



08/12/2020

DRISCOLL BEVERLY

1337 N ELM ST RUSSELL, KS 67665-1619

Subject Property: 1337 N ELM ST, Russell, KS 67665, ,
Property ID Number: 084-148-27-0-10-13-00200-0-01

Dear Property Owner:

An inspection by our Division has determined the property listed above is in violation of City Ordinance Article 2; Section 8-201

The following action must be taken to correct the above stated violation:

Remove trash & debris, Indoor Furniture, Appliances, Discard items in trailers.

Fines, liens or special assessments may be placed on the property for noncompliance and/or the costs of abatement, repair or demolition by the City.

Nuisances as defined in Section 8-201 include without limitation: Filth, excrement, lumber, rocks, dirt, cans, paper, trash, metal, articles or things whatsoever caused, kept, maintained or permitted by any person to the injury, annoyance or inconvenience of the public or of any neighborhood. You have ten (10) days from the receipt of this notice to either abate these violations, or request a hearing, in writing, before the Governing Body as provided by The Code of the City of Russell. Failure on your part to either abate these violations or request a hearing within the time allowed will result in a complaint being filed as provided by Section 8-208 and/or abatement as provided by Section 8-209 or Chapter VIII of the Code of the City of Russell. If the city abates the nuisance pursuant to section 8-209, the cost of abatement shall be charged against the lot or parcel of ground on which the nuisance was located. A copy of Chapter VIII of the Code of the City of Russell is available for your inspection at the City Building, 133 W. 8th Russell, Ks.

For further information, you may contact me at (785) 483-6311.

Date Served:

Tracking#: 7016 3560 0000 3259 7989

Sincerely,

Kim Grizzle

Code Enforcement Officer

Received By _____

7016 3560 0000 3259 7989

U.S. Postal Service
CERTIFIED MAIL® RECEIPT
Domestic Mail Only

For delivery information, visit our website at www.usps.com
RUSSELL KS 67665 SPECIAL USE

| | |
|---|-------------|
| Extra Services & Fees (check box, add fee as appropriate) | \$3.55 |
| Return Receipt (hardcopy) | \$2.00 |
| Return Receipt (electronic) | \$0.00 |
| Certified Mail Restricted Delivery | \$0.00 |
| Adult Signature Required | \$0.00 |
| Adult Signature Restricted Delivery | \$0.00 |
| Postage | \$0.55 |
| Total Postage and Fees | \$6.95 |
| Postmark | .50 |
| Total | 6.90 |

Sent to **Beverly Driscoll**
 Street and Apt. No., or PO Box No. **1337 N. Elm**
 City, State, Zip+4® **Russell, KS 67665**



COMPLETE THIS SECTION ON DELIVERY

A. Signature
 x **CON 19 KRC-4** Agent Addressee

B. Received by (Printed Name) **Beverly Driscoll** C. Date of Delivery **8-13-20**

D. Is delivery address different from item 1? Yes No
 If YES, enter delivery address below:
Same

3. Service Type

| | |
|--|---|
| <input type="checkbox"/> Adult Signature | <input type="checkbox"/> Priority Mail Express® |
| <input type="checkbox"/> Adult Signature Restricted Delivery | <input type="checkbox"/> Registered Mail™ |
| <input checked="" type="checkbox"/> Certified Mail® | <input type="checkbox"/> Registered Mail Restricted Delivery |
| <input type="checkbox"/> Certified Mail Restricted Delivery | <input checked="" type="checkbox"/> Return Receipt for Merchandise |
| <input type="checkbox"/> Collect on Delivery | <input type="checkbox"/> Signature Confirmation™ |
| <input type="checkbox"/> Collect on Delivery Restricted Delivery | <input type="checkbox"/> Signature Confirmation Restricted Delivery |
| <input type="checkbox"/> Insured Mail | |

Mail Restricted Delivery (00)

SENDER: COMPLETE THIS SECTION

- Complete items 1, 2, and 3.
- Print your name and address on the reverse so that we can return the card to you.
- Attach this card to the back of the mailpiece, or on the front if space permits.

1. Article Addressed to:
Beverly Driscoll
1337 N. Elm
Russell, KS. 67665

9590 9402 5042 9092 8241 73

2. Article Number (Transfer from service label)
7016 3560 0000 3259 7989

PS Form 3811, July 2015 PSN 7530-02-000-9053

Domestic Return Receipt









City Council Agenda Form

Meeting Date: September 15, 2020
Agenda Item Title: Special Event Application - Bricks, Broncs & BBQ/Car Show
Department: City Clerk

Agenda Item Description: Special Event Application Bricks, Broncs & BBQ/Car Show

Background: Russell Main Street will host their annual Bricks, Broncs & BBQ October 2, 2020 through October 3, 2020. Rotary will host their annual Flatland Car Show on October 3, 2020. Russell Main Street is asking for 8 Electric Drops, 8 Poly-Karts, 3 Dumpsters, Barricades, 4 Picnic Tables and 20 Rope Standers. Main Street is asking for a waiver of all fees. A map is included with the Special Event Application showing the street closures.

Also included is an application for a CMB License.

City Attorney Review/ Comment: N/A

Funding Source: N/A

Options:

1. Approve the special event application and CMB License as presented with waiver of fees.
2. Provide staff with alternate direction.
3. Take no action - The event will not be authorized.

Staff Recommendation: Approve the special event application and CMB License as presented with waiver of fees.

Attachment(s): Special Event Application/CMB License

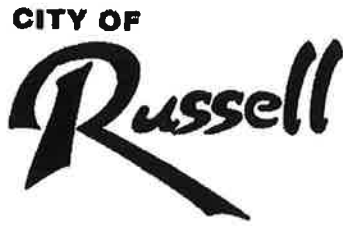

FEES:
Application Fee - \$25
Electric Drop (Includes usage) – \$100/drop (Fee increase may be applicable if special needs are determined)
Poly-Kart – \$5/cart
Dumpsters - \$30/dumpster
Barricades/Rope Standers – \$20/event
Picnic Tables – \$25 (includes up to 8 tables)
CMB Application – \$200

SPECIAL EVENT APPLICATION FORM

A complete application must be submitted at least ten days in advance of City Council Meeting, held on the third Tuesday of each month at 4:30 P.M.

Applicants must have a representative at the Council meeting or the application will not be approved.

Event Name: Bricks, Broncs & BBQ

Purpose/Description of Event: Attract people to downtown, boost sales, fundraiser

Applicant Information:

Date: 8/19/20

Name: Krista Whitmer

Company or Group: Russell Main Street, Inc.

Address: 207 E. 8th Street, Russell KS 67665

Phone Number: 785-483-2897

Cell Phone Number: 785-483-1951

Fax Number: _____

E-mail Address: mainstreet@eaglecom.net

Event Information:

Address: Downtown Russel, Cecil Bricker Park

Property Owner: City of Russell, Nancy Holland

Event Type:

X Type 1: Fundraising or non-commercial events for non-profit religious, educational, or community service organizations.

 Type 2: Promotional or commercial events and activities intended to be for-profit, or public events intended primarily for entertainment or amusement, such as concerts or festivals.

Please describe the proposed Special Event: Please see attached.

Proposed Dates: 10-2-20 to 10-3-20

Proposed hours of operation: 10-2-20 8am to 10-3-20 11:59 pm

***No more than four (4) Special Event Permits may be issued in a calendar year to the same applicant.**

Event Description: Please include the following information

****Applicant must visit with the Department Heads of the services requested and have them sign off.****

• **Electric Department**

- Electric Drop – # 8
- Voltage Needed _____ Amps _____ Location See map

• **Public Works**

- Poly-Karts - # 8
- Dumpsters - # 3

- Barricades – (Blocking public access to businesses or residences requires signatures of agreement from all affected by such closure, please include signatures on separate document) Describe detailed placement See attached.

- Picnic Tables - # 4
- Rope Standers - # 20

- **Police Department**

- Explain provisions for parking and security - The public will be able to park on side streets and Kansas Street. All area for beer garden will be roped off, IDs will be checked, 21 and older will wear bands. Security will be present during Brew Me.
- Anticipated Attendance - 500
- Describe proposed site maintenance; including how and when site will be cleaned following event. Site will be cleaned at the end of the event. Volunteers will collect trash. Tents will come down Sunday, 10-4, or Monday, 10-5. BBQ Teams will be informed of proper cleaning of sites and trash disposal.
- Note provisions, if any, that are being made for portable toilets (please include provider and disposal contractor) - Portable toilets will be provided by ASC Portables. Portable toilets will be placed behind Cecil Bricker Park and on the corner of 6th and Main.
- Identify any mobile food vendors associated with this proposed event – We will advertise mobile food vendor registration for Brew Me. A list of mobile food vendors will be provided if utilized. If a mobile food vendor registers a generator will be required if they are needing to plug in the trailer.
- Special Event Cereal Malt Beverage License (CMB) must be submitted in addition to Special Event Application, if Cereal Malt Beverages are to be served.

GRAPHIC DESCRIPTION: Please provide an aerial photograph or site plan of the area to include the following information:

- Location and dimensions of the event area
- Location and dimensions of any structures (tents, stages, etc) used for the event
- Location of requested amenities
- Any other information which pertains to the event

CHECKLIST:

- Completed Application
- Signatures for the use of barricades (Street Closures)
- Cereal Malt Beverage License Application
- Detailed Graphic Description

***Please note: Certain fees may be waived by City Council, if proposed event fits the Type 1 criteria.**











***Please submit application, required documents, and payment to City Clerk's office at least 10 days prior to regularly scheduled City Council Meeting.**

| | | |
|--|-------------------------------|--------------------------------|
| For Office Use Only: | | |
| Date Remitted: _____ | Cash/CC/Check# _____ | Receipt# _____ |
| Reviewed by: | | |
| Police Dept. <u>DW 8-26-2020</u> | Fire Dept. <u>[Signature]</u> | Public Works <u>RK 8/25/20</u> |
| Electric Dept. <u>[Signature] 9/8/2020</u> | City Clerk <u>[Signature]</u> | |
| Permit Number: _____ | Date Approved: _____ | |

- Description of Event:
 - Bricks, Broncs & BBQ is an event organized to enhance Downtown Russell by attracting community members, visitors, etc to Downtown to participate in the many festivities taking place throughout the weekend. The event consists of a Local BBQ Competition, Cornhole Tournament, Pie Baking Contest, Beer Garden, Community BBQ Sale, Kids Zone, Craft Brew Festival, and Entertainment.
- Proposed Special Event:
 - Bricks, Broncs & BBQ will kick-off at 8 am on Friday, October 2nd with the arrival of the BBQ Teams. The BBQ Teams will get checked in as they arrive and will continue to prepare for the BBQ Bucks Sale. The BBQ Sale and Beer Garden will start at 5 pm on Friday, October 2nd. Also on Friday, the Cornhole Tournament will take place. Registration will begin at 5:30 pm and the tournament will begin at 6:30 pm. DJ Entertainment will be provided in the tent during the Cornhole Tournament. At midnight on Friday evening the Beer Garden will close. On Saturday, October 3rd the BBQ Competition, Kids Zone, Pie Baking Contest, Vendors on Main Street, Main Street Beer Garden, Flatland Car Show, and Brew Me (microbrew and wine festival) will take place. The BBQ contest will begin at 11 am and end at 12:30 pm with awards at 2 pm. Kids Zone is a place for all things kids, we will invite organizations to provide activities at low or no cost for kids to enjoy, this will take place from 10 am to 2 pm. The Pie Baking Contest will begin at 11 am and end at 1 pm, this year the Pie Baking Contest will take place at Espresso, Etc. After the Pie Contest we will have our annual Used Pie Sale. Vendors will be set up on the sidewalks of Downtown Russell from 10 am to 2 pm. The Main Street Beer Garden will be open all day on Saturday. Flatland Car Show, organized by Rotary, will also take place on Saturday from 8 am until 3 pm. New this year we will add a Microbrew and Wine Festival called Brew Me. Brew Me will take place from 5 pm until 8 pm with VIP Session from 5 to 6 pm and General Admission from 6 to 8 pm. Brew Me has been added to the list of events in order to offer an addition activity for those traveling back to Russell for the All Class Reunion.
 - Additional information on Brew Me
 - Brew Me will consist of Russell Main Street, Inc. inviting select breweries and wineries to Downtown Russell. They will be asked to provide 2 oz samples of their product of choice to attendees. Main Street will sell VIP and general admission tickets to those who would like to attend. The tickets will be limited to 300 sold. Brew Me will take place under the big tent on 8th Street in between Main St. and Kansas St. The event is only for individuals 21 years and older.
- Barricades:
 - Friday, October 2nd starting at 6:00 am
 - 8th street in between Main Street and the alley way – blocked off for tent set-up
 - Friday, October 2nd starting at 8:00 am until Saturday, October 3rd at 11:59 pm
 - 9th street to 8th street on Main blocked off
 - 8th street in between Main Street and Kansas Street blocked off

- Tent will be set up Friday, October 2nd early am and will remain up until Sunday afternoon (10-4-20) or early Monday morning (10-5-20).
- Friday, October 2nd starting at 8:00 am until Saturday, October 3rd at 5:00 pm
 - 8th street in between USD 407 and Sunflower Bank from Main Street to the alley way blocked off
- Friday October 2nd starting at 4:00 pm until Friday October 2nd at 11:59 pm
 - North half of 8th street to 7th street on Main blocked off
- Saturday October 3rd at 8:00 am until Saturday October 3rd at 4:00 pm
 - 8th street to Wisconsin on Main blocked off for Car Show
 - Wisconsin to 5th street on Main potentially blocked off for Car Show



- | | |
|--|---|
|  Corn Hole Tournament - Friday |  Flat Lander Car Show - Saturday |
|  Drinking Area - Friday Night Only |  Drinking Area - Saturday Night Only |
|  Kids Zone Saturday 10AM-2PM |  Beer Garden - All Event |
|  Street Closed Friday & Saturday |  Trash Dumpster |
|  Street Closed Saturday Only |  Tent Locations |









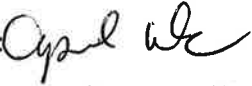

We are requesting to have the 600 and 700 block of Main St closed on October 3, 2020 for the Flatland Car Show. Since you have a business located in these blocks, please provide your signature below as acknowledgement and approval of closing Main Street on October 5, 2019 for the Flatland Car Show.

| | |
|---------------------|--|
| 740 N. Main Ste 201 | Sandy Wendt Bookkeeping Service _____ |
| 740 N. Main Ste 202 | Midwest Health Systems, Inc. _____ |
| 740 N. Main Ste 203 | Steckel Trucking _____ |
| 740 N. Main Ste 204 | Fred Weigel Jr. & Leon _____ |
| 740 N. Main Ste 205 | GPHA <u>Jana Seels</u> _____ |
| 740 N. Main Ste 206 | GPHA Training Room <u>Jana Seels</u> _____ |
| 740 N. Main Ste 207 | Mark Popp Tax Favored Benefits _____ |
| 731 N. Main | Off the Vine _____ |
| 726 N. Main | Jerry Driscoll Law Office _____ |
| 725 N. Main | Crystal Waymaster Salon _____ |
| 710 N. Main | Krug Auction & Realty _____ |
| 708 N. Main | Wadell & Reed _____ |
| 704 N. Main | Jagged Edge _____ |
| 624 N. Main | Miscellany Antiques _____ |
| 618 N. Main | Holland & Holland <u>M</u> _____ |
| 610 N. Main | 610 Yoga and Massage _____ |
| 604 N. Main | D. Palma & Mercantile Co. _____ |







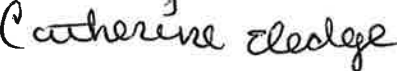



Gudenkart : Malone - Paula Shults
 Noelks - Dawn Wald

Insurance Planning - Emily Funderburk

Bricks, Broncs BBQ 20 - Road Closure Signature

1. 832 N. Main: VACANT
2. 830 N. Main: VACANT
3. Blehm Law Office – 826 N. Main: 
4. Deines Cultural Center – 820 N. Main: 
5. Rose Residence - 812 N. Main: 
6. The Bar/Holland Residence - 810 N. Main: 
7. USD 407 - 802 N. Main: 
8. Sunflower Bank- 740 N. Main: 
9. Sunflower Bank – 740 N. Main (Upper Story Suites): 
10. 809 N. Main: VACANT
11. The Mecca Plaza – 815 N. Main: 
12. A Full House – 825 N. Main - 
13. 835 N. Main - VACANT
14. 839 N. Main - VACANT

~~Downing Market~~ Car Show
Downing Market Road Closure Signature

1. Sunflower Bank – 740 N. Main:
2. Jerry Driscoll Law Office – 726 N. Main: 
3. OPI - 724 N. Main: 
4. Sunflower Design - 718 N. Main: VACANT
5. Gregwire Drug Store - 714 N. Main: 
6. Krug Auction & Realty - 710 N. Main: VACANT
7. Waddell & Reed - 708 N. Main: 
8. Jagged Edge - 704 N. Main:
9. Myers North - 737 N. Main & Myers South 703 N. Main: 
10. Bombshells- 731 N. Main: 
11. The Closet Boutique - 727 N. Main:
12. Beautiful Images - 725 N. Main: 
13. Myers Furniture - 721 N. Main: 
14. Waudby's Sports Bar & Grill & - 719 N. & Chet's Place – 713 N. Main: 
15. Serendipity - 709 N. Main: 

CORPORATE APPLICATION FOR LICENSE TO SELL CEREAL MALT BEVERAGES

(This form has been prepared by the Attorney General's Office)

City or County of Russell

SECTION 1 – LICENSE TYPE

Check One: New License Renew License Special Event Permit

Check One:

License to sell cereal malt beverages for consumption on the premises.

License to sell cereal malt beverages in original and unopened containers and not for consumption on the licensed premises.

SECTION 2 – APPLICANT INFORMATION

Kansas Sales Tax Registration Number (required):

I have registered as an Alcohol Dealer with the TTB. Yes (required for new application)

| | | | |
|--|--|--|---|
| Name of Corporation Russell Main Street, Inc. | | Principal Place of Business Russell, KS | |
| Corporation Street Address 207 E. 8th Street | | Corporation City Russell | State KS |
| | | Zip Code 67665 | |
| Date of Incorporation 12-1991 | Articles of Incorporation are on file with the Secretary of State. | | <input checked="" type="checkbox"/> Yes <input type="checkbox"/> No |
| Resident Agent Name Nancy Holland | | Phone No. 785-483-0411 | |
| Residence Street Address 210 N. Fossil | | City Russell | State KS |
| | | Zip Code 67665 | |

SECTION 3 – LICENSED PREMISE

| Licensed Premise (Business Location or Location of Special Event) | Mailing Address (if different from business address) |
|--|---|
| DBA Name Cecil Bricker Park | Name Nancy Holland |
| Business Location Address 805 N. Main | Address PO Box 206 |
| City Russell, KS 67665 | City Russell, KS 67665 |
| State | State |
| Zip | Zip |
| Business Phone No. 785-483-0411 | <input type="checkbox"/> Applicant owns the proposed business location. <input checked="" type="checkbox"/> Applicant does not own the proposed business location. |
| Business Location Owner Name(s) Nancy Holland | |

SECTION 4 – OFFICERS, DIRECTORS, STOCKHOLDERS OWNING 25% OR MORE OF STOCK

List each person and their spouse*, if applicable. Attach additional pages if necessary.

| | | |
|--|--------------------------------|-----------------------------|
| Name Krista Whitmer | Position Executive Director | Date of Birth [REDACTED] |
| Residence Street Address 627 W. 2nd Street | City Russell | State KS |
| | Zip Code 67665 | |
| Spouse Name Brian Whitmer | Position | Date of Birth [REDACTED] |
| Residence Street Address | City | State |
| | Zip Code | |
| Name Kayla Schneider | Position Board President | Date of Birth [REDACTED] |
| Residence Street Address 112 Cindy Dr. | City Russell | State KS |
| | Zip Code 67665 | |
| Spouse Name Brian Schneider | Position | Age [REDACTED] |
| Residence Street Address | City | State |
| | Zip Code | |
| Name Cammy Uehling | Position Board Member | Date of Birth [REDACTED] |
| Residence Street Address 3715 Thunderbird Dr. | City Hays | State KS |
| | Zip Code 67601 | |
| Spouse Name Brennan Uehling | Position | Age [REDACTED] |
| Residence Street Address 3715 Thunderbird Dr | City Ha | State KS |
| | Zip Code 67601 | |

SECTION 4 – OFFICERS, DIRECTORS, STOCKHOLDERS OWNING 25% OR MORE OF STOCK (CONTINUED)

| | | |
|---|---|------------------------------------|
| Name Kelli Johnson | Position Board Treasurer | Date of Birth [REDACTED] |
| Residence Street Address 310 S. Elm | City Russell State KS | Zip Code 67665 |
| Spouse Name Eddie Johnson | Position | Date of Birth [REDACTED] |
| Residence Street Address 310 S. Elm | City Russell State KS | Zip Code 67665 |

| | | |
|---|---|------------------------------------|
| Name Kristen Windscheffel | Position Board Member | Date of Birth [REDACTED] |
| Residence Street Address 307 E. 3rd St. | City Russell State KS | Zip Code 67665 |
| Spouse Name Jake Windscheffel | Position | Date of Birth [REDACTED] |
| Residence Street Address 307 E. 3rd St. | City KS State KS | Zip Code 67665 |

| | | |
|---|---|------------------------------------|
| Name Sarah Depiesse | Position Board Member | Date of Birth [REDACTED] |
| Residence Street Address 747 E. 7th | City Russell State KS | Zip Code 67665 |
| Spouse Name Kelly Depiesse | Position | Date of Birth [REDACTED] |
| Residence Street Address 747 E. 7th | City Russell State KS | Zip Code 67665 |

| | | |
|--|---|------------------------------------|
| Name Amber Ruggels | Position Board Secretary | Date of Birth [REDACTED] |
| Residence Street Address 918 E. 2nd Street | City Russell State KS | Zip Code 67665 |
| Spouse Name Brady Ruggels | Position | Date of Birth [REDACTED] |
| Residence Street Address 918 E. 2nd Street | City Russell State KS | Zip Code 67665 |

| | | |
|---|---|------------------------------------|
| Name Mandy Funk | Position Board Member | Date of Birth [REDACTED] |
| Residence Street Address 2093 NW 90th Ave | City Russell State KS | Zip Code 67665 |
| Spouse Name Deric Funk | Position | Date of Birth [REDACTED] |
| Residence Street Address 2093 NW 90th Ave | City Russell State KS | Zip Code 67665 |

| | | |
|--------------------------|------------|---------------|
| Name | Position | Date of Birth |
| Residence Street Address | City State | Zip Code |
| Spouse Name | Position | Date of Birth |
| Residence Street Address | City State | Zip Code |

| | | |
|--------------------------|------------|---------------|
| Name | Position | Date of Birth |
| Residence Street Address | City State | Zip Code |
| Spouse Name | Position | Date of Birth |
| Residence Street Address | City State | Zip Code |

| | | |
|--------------------------|------------|---------------|
| Name | Position | Date of Birth |
| Residence Street Address | City State | Zip Code |
| Spouse Name | Position | Date of Birth |
| Residence Street Address | City State | Zip Code |

| SECTION 5 – MANAGER OR AGENT INFORMATION | | |
|---|----------------------------------|---|
| My place of business or special event will be conducted by a manager or agent. | | <input checked="" type="checkbox"/> Yes <input type="checkbox"/> No |
| If yes, provide the following: | | |
| Manager/Agent Name Krista Whitmer | Phone No. 785-483-1951 | Date of Birth ██████████ |
| Residence Street Address 627 W. 2nd St. | City Russell | Zip Code 67665 |
| Manager or Agent Spousal Information* | | |
| Spouse Name Brian Whitmer | Phone No. 785-658-6051 | Date of Birth ██████████ |
| Residence Street Address 627 W. 2nd St. | City Russell | Zip Code 67665 |
| SECTION 6 – QUALIFICATIONS FOR LICENSURE | | |
| Within 2 years immediately preceding the date of this application, have any of the individuals identified in Sections 4 & 5 have been convicted of, released from incarceration for or released from probation or parole for any of the following crimes*: (1) Any felony; (2) a crime involving moral turpitude; (3) drunkenness; (4) driving a motor vehicle while under the influence of alcohol (DUI); or (5) violation of any state or federal intoxicating liquor law. | | <input type="checkbox"/> Yes <input checked="" type="checkbox"/> No |
| Have any of the individuals identified in Sections 4 and 5 been managers, officers, directors or stockholders owning more than 25% of the stock of a corporation which: (1) had a cereal malt beverage license revoked; or (2) was convicted of violating the Club and Drinking Establishment Act or the CMB laws of Kansas. | | <input type="checkbox"/> Yes <input checked="" type="checkbox"/> No |
| All of the individuals identified in Sections 4 & 5 are at least 21 years of age*. | | <input checked="" type="checkbox"/> Yes <input type="checkbox"/> No |
| SECTION 7 – DURATION OF SPECIAL EVENT | | |
| Start Date October 2, 2020 | Time 8:00 | <input checked="" type="checkbox"/> AM <input type="checkbox"/> PM |
| End Date October 3, 2020 | Time 11:59 | <input type="checkbox"/> AM <input checked="" type="checkbox"/> PM |

Proceed to Section 8 on the next page.

SECTION 8 – LICENSED PREMISE

In the space below, draw the area you wish to sell or deliver CMB. Include entrances, exits and storage areas. Do not include areas you do not wish to license. If you wish to attach a drawing, check the box: 8 1/2" by 11" drawing attached.

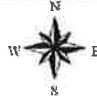

I declare under penalty of perjury under the laws of the State of Kansas that the foregoing is true and correct and that I am authorized by the corporation to complete this application. (K.S.A. 53-601)

SIGNATURE [Handwritten Signature] DATE 9-3-2020

FOR CITY/COUNTY OFFICE USE ONLY:

License Fee Received Amount \$ 200 Date 9/8/2020
(\$25 - \$50 for Off-Premise license or \$25-200 On-Premise license)

\$25 CMB Stamp Fee Received Date 9/10/20

Background Investigation Completed Date 9-10-2020 ^{DCW} Qualified Disqualified

Verified applicant has registered with the TTB as an Alcohol Dealer

New License Approved Valid From Date _____ to _____ By: _____

License Renewed Valid From Date _____ to _____ By: _____

Special Event Permit Approved Valid From Date _____ to _____ By: _____

A PHOTOCOPY OF THE COMPLETED FORM, TOGETHER WITH THE STAMP FEE REQUIRED BY K.S.A. 41-2702(e), MUST BE SUBMITTED WITH YOUR MONTHLY REPORT (ABC-307) TO THE ALCOHOLIC BEVERAGE CONTROL, 915 SW HARRISON STREET, TOPEKA, KS 66612.

* Applicant's spouse is not required to meet citizenship, residency or age requirements. If renewal application, applicant's spouse is not required to meet the no criminal history requirement. K.S.A. 41-2703(b)(9)



Maple Street

ELECTRIC DROPS

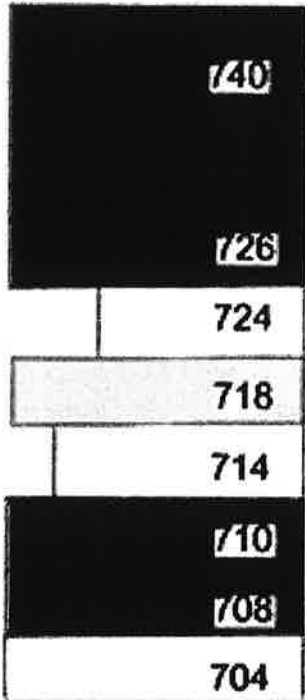
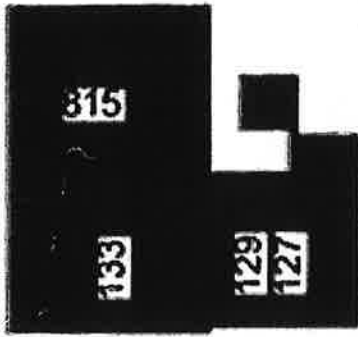

Main Street

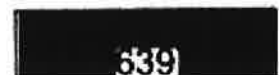
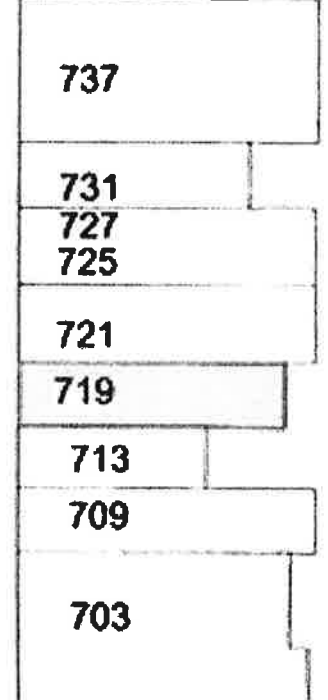
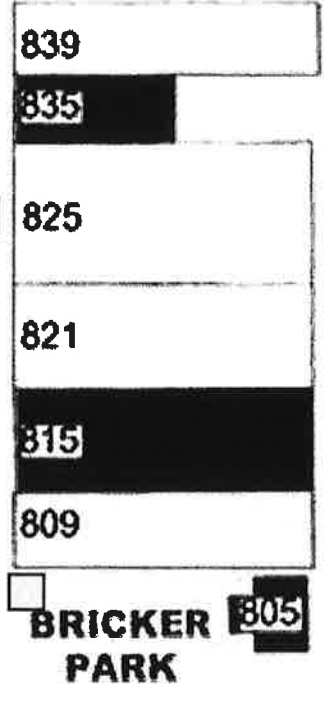



City Council Agenda Form

Meeting Date: September 15, 2020

Agenda Item Title: Review and Consideration of Bids for Sanitation Truck Replacement

Department: Public Works

Agenda Item Description: Sanitation Truck Replacement Bids

Background: With the council authorizing the creation of the Sanitation Reserve Fund, the purpose of this fund is purchases of large capital expenses of a trash truck budgeted every three years. The city maintains two trash trucks in it's inventory. One is a 2017 Freight Liner with a PakMor Refuse body. The other is 2012 Sterling with a Nu-Way. These two trucks are used together on Friday's routes, to get through the five day work schedule. On the other days of the work week, the 2017 Freight Liner is just used and the older unit used for a back up. If council approves of the purchase, the 2012 will be taken out of service and sold on public auction. Staff solicited bids from three companies for a Peterbilt 337 with a 20 yard Refuse Body.

1. Key Equipment bid of \$169,804.00 for a Peterbilt 337chassis with a Leach Alpha III.
2. Armour Equipment bid of \$152,080.80 for a Peterbilt 337 chassis with a Heil PT 1000.
3. TLG Trucks bid of \$153,823.00 for a Peterbilt 337 chassis with a LoadMaster Legacy.

Option of a two year or 2,000 hour warranty was included in the RFB. Staff recommends an extended 3 year warranty on the engine of \$900, and a 3 year on the HI-DEF of \$500.

City Attorney Review/ Comment: N/A

Funding Source: Sanitation Reserve Fund

Options:

1. Accept the lowest bid from Armour Equipment in the amount of \$152,080.80 not meeting the minimum specifications.
2. Accept the next lowest bid from The Larson Group Trucks in the amount of \$153,823.00 with meeting the minimum specifications and a heavier transmission.
3. Take no action and provide staff with further direction.

Staff Recommendation: Approve the purchase of a 2021 Peterbilt 337 with a 20 Yard Refuse Body from The Larson Group Trucks in the amount \$153,823.00 adding the chassis three year extended warranty of \$1,400.00.

Attachment(s): Two Bid Packets on Truck chassis and of the 20 Yard Refuse Body

City of Russell

Request for Bids

20-yard Rear Load Refuse Truck

Date of Issue:8/25/2020

Bid Due Date:9/7/2020

Introduction

The City of Russell is requesting bids for (20 Yard Rear Load Refuse Truck). Bids will be accepted until 12:00 PM 9/7/2020 at the City Building, 133 W. 8th St., PO Box 112, Russell KS 67665.

This written Request for Bids (RFB) states the scope of the City of Russell requirements and specifies general rules preparing the bid.

The bid should clearly demonstrate how the vendor can best satisfy the requirements of the City of Russell. The City of Russell shall reserve the right to award the purchase order which is most advantageous to the City of Russell.

Rules of Preparation

The submitted bid must follow the rules and format established within this RFB. Adherence to these rules will ensure a fair and objective analysis of all bids. Failure to comply with any portion of this request may result in rejection of a bid.

Vendor Inquiries

The Sanitation Department of the City of Russell has prepared this RFB and has designated (Chadd Stevenson, Street Superintendent) as project manager. Please direct questions or comments concerning either the administrative or technical requirements of this RFB to the project manager.

Chadd Stevenson, Street Superintendent
City of Russell
PO Box 112
Russell, KS 67665
785.483.6311 office
Chadd@russellcity.org

To ensure a timely response, questions should be emailed to the Project Manager at the specified address listed above.

Submission of Bids

Please prepare and submit one (1) original and two (2) copies of the bid. Completed bids should be sealed and clearly marked "(20-yard Rear Load Refuse Truck)" in bold or highlighted text with strict instructions not to open until the due date and be submitted to the Project Manager by the due date.

Bids received after the above date and time will be considered late and will not be accepted. Responses will be evaluated objectively based on the vendor's response to the RFB.

The City of Russell will not pay costs incurred in the bid preparation including but not limited to the costs for printing, demonstration, negotiations process, etc. All costs for the preparation of the bid shall be borne by the proposing vendor.

Notification of Withdrawal of Bid

Bids may be modified or withdrawn by an authorized representative of the vendor or by formal written notice prior to the final due date and time specified for bid submission. Otherwise, bids will be considered valid for at least sixty (60) days from the opening date. Submitted bids will become the property of the City of Russell after the bid submission deadline.

Minimum Specifications and Scope of Project

See Attachment "B" for Bid Instructions and Minimum Specifications

Contractual Obligations

The successful vendor will be required to accept a purchase order from the City of Russell in which the vendor will undertake certain obligations. These obligations include, but are not limited to, the following:

Non-limitations to RFB

The format of the RFB must be followed and all requested information must be submitted as indicated; however, the City of Russell is receptive to any additional suggestions pertaining to services development, additional related capabilities, and any alternative methods for providing related services. Any exceptions to the RFB terms and conditions must be included in writing in the bid.

Interpretations and addenda

No interpretation made to any respondent as to the meaning of the RFB shall be binding on the City of Russell unless repeated in writing and distributed as an addendum by the City of Russell. Interpretations and/or clarification shall be requested writing from the Project Manager.

Bid Response Format

In order to facilitate the analysis of response to this RFB, vendors are required to prepare their bid in accordance with the instructions outlined in this section. Each vendor is required to submit the bid documents in response to the RFB in a sealed envelope. Vendors whose bids deviate from these instructions may be considered nonresponsive and may be disqualified at the discretion of the City of Russell.

Bids should be prepared as simply as possible and provide a straightforward, concise description of the vendor's capabilities to satisfy the requirements of the RFB. Expensive bindings, promotional material, etc., are not necessary or desired.

Emphasis should be concentrated on accuracy, completeness, and clarity of content. The bid should be submitted on the Bid Sheet provided.

Confidentiality of Documents

All responses to the RFB submitted by vendors shall be deemed public documents at the time opened by the City of Russell. The RFB is intended to be worded in a manner so as not to elicit proprietary information from the vendor. If proprietary information is submitted as part of the bid, such information is to be labeled proprietary and be accompanied with a request that the information is to be returned by the City of Russell to the submitter. Any bid that is submitted with a blanket statement or limitation that would prohibit or limit such public inspection shall be considered non-responsive and shall be rejected.

Legal Notice

The City of Russell reserves the right to reject any and all bids and waive any or all technicalities, as determined by the City Manager of the City of Russell.

The City of Russell expects a professional job, done commensurate with the standards and practices of the profession/or business.

All persons awarded and/or entering into purchase orders with the City of Russell shall be subject to and required to comply with all applicable City, State and Federal provisions.

**CITY OF RUSSELL
Sanitation Department**

**BID INSTRUCTIONS
FOR
20-yard rear load refuse truck**

GENERAL

The specifications and dimension that follow shall apply to the purchase of one (1) 20-yard rear load refuse truck for the City of Russell, Kansas. The City reserves the right to waive minor technicalities under this specification.

The 20-yard rear load refuse truck shall be a 2020 or newer; new and unused, under standard production by the manufacturer, and of which parts are stocked at one or more locations in Kansas or Great Kansas City. All parts on the 20-yard rear load refuse truck shall be new and unused. Bidder must be a manufacturer's authorized dealer for the product represented in their bid, and will be held responsible for the submission of proper information to the manufacturer.

The bidder agrees, if his proposal is accepted, to guarantee the design, material and workmanship of the refuse truck according to the standard factory warranty, or for one year, whichever is greater. **A copy of the warranty shall accompany the bid.** All service called for in the standard warranty shall apply without exception. Warranty coverage shall include costs incurred in the transportation of the refuse truck to and from the dealer's shop, if required, or travel time and expenses to and from the City of Russell's facilities, should warranty work be performed in the field.

Complete specifications and literature on the refuse truck shall accompany the bid. Any exceptions to these specifications shall be indicated on the bid or on a separate attachment to the bid, labeled as such.

Any "Or Approved Equal" or "equivalent" (OAE) items for brand specified components shall be listed with the bid package. Complete description and literature on the "equivalent" components shall be supplied for consideration by the City. The burden of proof regarding the "equivalent" shall be upon the vendor.

DELIVERY

The refuse truck shall be delivered complete and fully operational to the Street Department at 333 East 9th St. Russell, KS. The refuse truck must comply with all applicable Federal and State regulations. It shall be properly serviced, free of leaks, and all mechanical adjustments made prior to delivery. A minimum of three (1) business days' notice shall be given prior to delivery. Delivery must be made between the hours of 8:00 a.m. and 3 p.m. weekdays.

All costs associated with transportation will be bidder's responsibility.

The refuse truck with missing equipment or otherwise failing to meet specification shall not be accepted and shall become the vendor's responsibility.

A dealer's representative shall provide instructions on the proper operation and maintenance at the time of delivery.

TECHNICAL SERVICE

The services of a competent technician, thoroughly knowledgeable in the use, operation and servicing of the refuse truck, shall instruct City personnel in the proper use, safety, operation and preventative maintenance of the refuse truck and test the refuse truck for satisfactory performance. This instruction shall be performed on a date to be agreed upon by the Street Superintendent.

OPTIONS

The following items shall be bid as **OPTIONS** and shall be quoted individually as indicated on the Bid Form and shall reflect those costs in addition to the **BASE BID**. It shall be understood that the City of Russell may select any variety of the listed options.

OPTION #1 – 2 year or 2,000-hour warrant.

TRADE-IN INFORMATION

The City of Russell will **NOT** have a vehicle for trade-in:

TAXES

This purchase is **NOT** tax exempt. Appropriate certification will be supplied to vendor upon request.

BID SHEET
One (1) 20-yard rear load refuse truck

BRAND AND MODEL: Detroit Diesel 671000

YEAR: 2020

APPROXIMATE DELIVERY DATE: 8-10 weeks

WARRANTY: See attached chassis / 8 body

ALL OPTIONS SHALL REFLECT THOSE COSTS IN ADDITION TO THE BASE BID

DELIVERED F.O.B. TO CITY OF RUSSELL, 333 E. 9th St.

| | OUT-RIGHT PRICE | TRADE-IN CREDIT | TOTAL |
|--|---|-----------------|----------------------|
| BASE BID- (LIST ITEM HERE) | \$ <u>152,050.80</u> | <\$_XXX_> | \$ <u>152,050.80</u> |
| OPTION #1 - 2 year or 2,000 hour warranty | <u>WEL EXTENDED BODY 13 TO 14 HO.</u> | | \$ <u>2,704.00</u> |
| TOTAL BID | | | \$ <u>154,754.80</u> |

REPRESENTATIVE Steve Simpson

COMPANY Beaver Equipment

ADDRESS 450 N. Lincoln Ave, Olathe, MO 66062

TELEPHONE NUMBER 816-743-1212 DATE 9-2-2020

COMMENTS _____

Cab and Chassis

1. **Application**
 - a. The chassis shall be capable of carrying the net weight of a 20 yard refuse body, plus the weight of the refuse to be collected.
 - b. The chassis shall be designed to accommodate the refuse body that is used daily for the removal of both commercial and residential refuse.
 - c. The chassis shall be capable of both a minimum of 55 mph. speeds and frequent starts and stops.

2. **Model**
 - a. The base chassis model shall be a Peterbilt model 337. YES/NO
 - b. The equipment furnished under these specifications shall be new, 2020 or newest model available. YES/NO
 - c. The vehicle shall come complete with all accessory equipment including the operation and service manuals. YES/NO

3. **Axles and equipment**
 - a. The front axle shall be rated at 10,000 lbs. YES/NO
 - b. The front axle shall have tapered leaf springs with 10,000 lbs. shocks. YES/NO
 - c. The rear axle shall be rated at 23,000 lbs. YES/NO
 - d. The rear axle shall be of multi leaf design rated at 30,000 lbs. YES/NO
 - e. The vehicle shall have a gross combined weight of 33,000 lbs. YES/NO

4. **Engine**
 - a. The vehicle shall come with a PACCAR PX9 engine. YES/NO
 - b. The vehicle shall have engine protection shutdown. YES/NO
 - c. The engine shall have a PACCAR 160 amp alternator. YES/NO
 - d. The engine shall have a immersion style block heater 110-120v. YES/NO
 - e. The engine shall have a 2-speed fan clutch. YES/NO
 - f. The engine shall have a VGT exhaust brake. YES/NO
 - g. The engine shall have a spin-on fuel/water separator. YES/NO
 - h. The engine shall have a high efficient cooling system with ELC rated at -30 degrees Fahrenheit. YES/NO
 - i. The vehicle shall have a single right hand side exhaust. YES/NO

5. **Transmission and equipment**
 - a. Vehicle shall come with an Allison 3000 series RDS-P transmission. YES/NO
 - b. The Allison transmission shall have a six speed configuration. YES/NO
 - c. The vehicle shall have a dash mounted push button shifter. YES/NO
YES/NO

6. **Fuel tanks**
 - a. The vehicle shall have a minimum of a 60 gallon fuel tank located on the left hand side. YES/NO

7. **Cab and equipment**
 - a. The vehicle shall come with an 108" aluminum cab. YES/NO
 - b. The cab shall come with the thermal insulation package. YES/NO

Cab and Chassis

- c. The drivers seat shall be of high back, air ride, vinyl design. YES/NO
- d. The two (2) person passenger seat shall be of low back, non-air ride, vinyl design. YES/NO
- e. The steering column shall be capable of both tilt and telescoping. YES/NO
- f. The interior shall be grey/black in color. YES/NO
- e. The cab shall be of day cab design. YES/NO
- f. The cab shall come with a combination of both fresh air heater and air conditioning. YES/NO
- g. The vehicle shall come with the Peterbilt Comfort Control Cab. YES/NO
- h. The cab shall come with AM/FM radio with standard two (2) speaker package. YES/NO

Refuse Body

Its the intent of these specification to describe the min. requirements for a refuse collection body of a rear load design.

1. Application

- a. Features standard to this unit will be furnished by the successful bidder. Body shall conform in strength, quality of material and workmanship to that provided by the best engineering and manufacturing practice of the industry.
- b. All equipment shall be of the newest design, assembled and ready for operation at the time of delivery.
- c. Bidder shall attach a statement that the unit meets or exceeds these specifications and/or list any exceptions fully and accurately.

2. General

- a. Refuse body will have a capacity of 20 yards.
- b. Packer body will be able of packing 900 pounds per cubic yard of dry commercial and residential refuse.
- c. Packer body must meet all applicable ANSI Z245.1 safety standards.
- d. PTO is to be of "Hot Shift" design.
- e. Hydraulic kick bar device to lift and dump 3 cubic yard commercial containers, including trunnion locks to lock containers into position along with associated hydraulic components.
- f. (2) Perkins cart tippers. Tippers must tuck away when not in use, and clear the kick bar in all positions.

3. Body construction

- a. Body shall be of all welded construction. YES/NO
- b. All pivot points shall be provided with grease zerks. YES/NO
- c. The sides of the body shall be constructed of 10 gauge, 80,000 psi. steel. YES/NO
- d. The roof of the body shall be constructed of 10 gauge, 80,000 psi. steel. YES/NO
- e. The floor of the body shall be constructed of 10 gauge, 80,000 psi. steel. YES/NO
- f. A side access door shall be located on the left (street) side of the body. The door should be approximately 30" X 30" that allows for the operator to access eject controls and tailgate lift controls w/out door being open. YES/NO
- g. No hydraulic cylinders, valves or any hydraulic components shall come into contact with refuse packed into body. YES/NO

4. Body dimensions

- a. The outside width of the body shall not exceed 102" YES/NO
- b. The overall length of the body including tailgate shall not exceed 234". YES/NO
- c. The overall height of the body above frame shall not exceed 96". YES/NO

Refuse Body

Its the intent of these specification to describe the min. requirements for a refuse collection body of a rear load design.

5. Hopper

- a. The hopper capacity shall not be less then 3.0 cubic yards. YES NO
- b. The hopper floor shall be constructed of a minimum of 3/16", 100,000 psi steel. YES NO
- c. The hopper sides shall be constricted of a minimum of 3/16", 50,000 psi steel. YES NO
- d. The hopper opening width shall be shall be a minimum of 84". YES NO
- e. The hopper opening height shall be a minimum of 62". YES NO
- f. The hopper depth shall be a minimum of 16" from top of load sill. YES NO
- g. The hopper load sill height is no greater than the chassis frame height. YES NO
- h. The hopper shall be equipped with an 1 1/2" drain plug. YES NO

6. Tailgate

- a. The tailgate shall be raised by two (2) 3 1/2" bore cylinders mounted on the outside of the tailgate. YES NO
- b. The two (2) lift cylinders must be equipped with flow restrictors to prevent sudden decent. YES NO
- c. The tailgate shall be equipped with a rubber seal to provide a water tight seal between the body and tailgate. The seal must extend a minimum of 36" up the sides. YES NO
- d. The tailgate shall be constructed of 10 gauge, 80,000 psi. steel. YES NO
- e. Bolt on riding steps shall be provided on each side, constructed of grip strut. Each step shall have two (2) 1" diameter grab handles. YES NO

7. Packer

- a. The packer cycle time shall not exceed 23 seconds with a reload time of 8 seconds. *BETTER*
 YES NO
- b. The packer face plate thickness shall be 3/16", 50,000 psi. steel. YES NO
- c. The packer face plate compacts material into the body against the ejector panel and the roof of the body, not the front of the hopper. YES NO
- d. The packer shall be capable of packing 900 pounds per cubic yard of dry commercial and residential refuse. *BETTER*
 YES NO

8. Ejector

- a. The load shall be ejected by a double acting, telescopic hydraulic cylinder that shall extends and retracts the ejector panel the full length of the body without the use of clamp bars or related hardware. YES NO

Refuse Body

Its the intent of these specification to describe the min. requirements for a refuse collection body of a rear load design.

- b. The ejector panel will travel on friction reducing composite material that can be easily replaced without removing the panel from the body. YES/NO
- c. No part of the panel shall protrude into the hopper when its in its rear most position. YES/NO
- d. The ejector panel shall have a 10 gauge hi-tensile steel face. YES/NO
- e. The ejector panel shall hold pressure against the compacted material and must automatically "drift" forward by a hydraulic load control valve with out any operator assistance. YES/NO

9. Hydraulics

- a. The hydraulic system shall be designed for easy maintenance. YES/NO
- b. The hydraulic pump shall provide a minimum of 30 GPM. At 1000RPM. YES/NO
- c. The hydraulic system shall incorporate an adjustable main relief valve. YES/NO
- d. The hydraulic reservoir shall have a minimum capacity of 30 gallons of oil. YES/NO
- e. The hydraulic reservoir shall be equipped with a filler/breather cap, sight glass, clean out cover, 100 micron suction filter, magnetic tank drain plug and a shut off valve on the suction side. YES/NO
- f. The hydraulic reservoir shall be mounted inside the body. YES/NO
- g. A replaceable 10 micron filter with a bypass valve and visible sight indicator shall be incorporated in the hydraulic system. YES/NO
- h. All multi spool circuit valves shall be of sectional construction, to allow replacement of defective valve with out replacing the entire valve assembly. YES/NO
- i. All hydraulic hoses are to be SAE. Approved construction. All hoses shall have a burst pressure four (4) times greater than the working pressure. YES/NO
- j. Hydraulic tubing is used where flexible hose is not needed. YES/NO
- k. Hydraulic hoses and tubing shall be secured by clamps as required to prevent damage from abrasion and vibration. YES/NO
- l. All hydraulic assemblies must be located so at no time or load condition it becomes necessary to remove the load to service or repair these components. YES/NO
- m. PTO is to be of "hot shift" design. YES/NO

10. Controls

- a. Controls for the packer are to be located on the right (curb) side at the rear of the tailgate. These controls must have the capacity to start, stop and reverse the packing mechanism. YES/NO

Refuse Body

Its the intent of these specification to describe the min. requirements for a refuse collection body of a rear load design.

- b. The tailgate lift and ejector controls shall be located on the left (street) side, located at the front inside the body. These controls shall be accessed through an opening located in the access door. Controls shall not come into contact with refuse and are protected from the outside elements. YES/NO
- c. Two (2) throttle advance switches shall be provided. One must be located at the right (curb) side near the packing controls. The second switch must be located at the front left (street) side of the body within easy reach of the tailgate and eject controls. This switch may be accessed from the outside of the body. YES/NO
- d. PTO pump controls are to be located in the cab. YES/NO
- e. The two (2) cart tipper controls shall be mounted a minimum of 44" from ground level. Each control shall be mounted on the corresponding side of the tailgate as the tipper itself. YES/NO
- f. One (1) single control lever for the hydraulic kick bar shall be mounted on the right (curb) side of the tailgate. This control shall be mounted a minimum of 44" from ground level. YES/NO

11. Electrical

- a. All electrical connectors shall be of weather tight design. (example. Weather pak or Deutsch) YES/NO
- b. All electrical wiring shall be color coded or labeled. YES/NO
- c. All electrical wired shall be in a braided harness or a loom. YES/NO
- d. All circuits shall be protected by a circuit breaker or fuse. YES/NO
- e. All body lights shall conform to FMVSS#108 regulations. YES/NO
- f. An addition set of stop, tail and turn signal lights shall be mounted above the hopper on a light bar. YES/NO
- g. Two (2) white working lights shall be mounted on the upper half of the tailgate, these lights must be capable of illuminating the hopper. These lights shall be activated from inside the cab. YES/NO
- h. Four (4) corner (LED) strobe lights shall be provided. YES/NO
- i. All lights must be of sealed design, recessed and gromet mounted. The working lights and tag light is exempt. YES/NO
- j. A rear vision camera system shall be provided. The monitor shall be mounted in the cab within easy view of the driver. YES/NO
- k. A backup alarm shall be provided. YES/NO
- l. Two (2) push button switches that alert the driver shall be provided. One mounted on each side of the tailgate. YES/NO
- m. A PTO "kill" switch shall be provided near the packing controls on the right (curb) side of the tailgate. YES/NO

Refuse Body

Its the intent of these specification to describe the min. requirements for a refuse collection body of a rear load design.

12. **Paint**
- n. An in cab light and buzzer shall alert the driver when the tailgate is ajar. YES NO
 - a. All welding slag shall be removed and any rough areas shall be smoothed prior to painting. YES NO
 - b. The entire body shall be properly cleaned and conditioned prior to painting. YES NO
 - c. A minimum of one (1) coat of primer with a rust inhibitor shall be applied to the body prior to painting. YES NO
 - d. A minimum of one (1) coat of white paint shall be applied to the body. Paint shall match the color of cab and provide a high gloss finish. YES NO
13. **Additional Accessories and requirements**
- a. A hydraulic kick bar to lift and dump 3 yard commercial containers shall be provided. This includes all accessories to lock containers in place. YES NO
 - b. Two (2) Perkins rotary cart tippers shall be provided. YES NO
 - c. The cart tippers shall be of tuck away design and clear the hydraulic kick bar in any and all positions. YES NO
 - d. The overall height of combined unit (body mounted to chassis) shall not exceed 11'8" at it highest point. YES NO
 - e. One (1) 10 pound fire extinguisher shall be mounted securely on the body and easily accessible to riders. YES NO
 - f. Mud flaps shall be provided ahead and behind the rear axle. YES NO
 - g. A complete Operation Manual and a Service Manual shall be provided. YES NO

Exception to bid Specifications

Line #

Explanation

ATTACH
3

WARRANTY NO ON ROAD (MATERIAL)
4 TRAVEL TIME TO DISPERSE
CRACKS / JOBS

LINE
4

PACKER CRACK TIME 15-17
REPAIR 6-8 SECONDS
UP TO 100 LBS PER YARD

LINE
13

2 6000 PAVING CRACK
1.5 HOURS



Doonan Pblt Of Grt. Bend (W281)
 36 Ne Hwy 156
 Great Bend, Kansas 67530

City Of Russell
 PO Box 112
 Russell, Kansas 67665
 United States of America

Bill Rowe
 Cell Phone: 620-793-0780
 Office Phone: 785-621-4045
 Email: bill_rowe@doonantruck.com

Chad Stevenson
 Cell Phone: 785-483-7807
 Office Phone: 785-472-7213

Vehicle Summary

| Unit | | Chassis | |
|-------------------------|--------------------------|----------------------------|-------|
| Model: | Model 337 | Fr Axle Load (lbs): | 10000 |
| Type: | Full Truck | Rr Axle Load (lbs): | 23000 |
| Description 1: | | G.C.W. (lbs): | 33000 |
| Description 2: | | | |
| Intended Serv.: | Application | Road Conditions: | |
| Commodity: | Refuse/Landfill | Class A (Highway) | 100 |
| | Refuse, Scrap, Recycling | Class B (Hwy/Mtn) | 0 |
| | | Class C (Off-Hwy) | 0 |
| | | Class D (Off-Road) | 0 |
| Type: | Body | Maximum Grade: | 6 |
| Length (ft): | Curbside Recycler | Wheelbase (in): | 208 |
| Height (ft): | | Overhang (in): | 45.8 |
| Max Laden Weight (lbs): | | Fr Axle to BOC (in): | 69.8 |
| | | Cab to Axle (in): | 138.2 |
| | | Cab to EOF (in): | 184 |
| No. of Trailer Axles: | Trailer | Overall Comb. Length (in): | 292 |
| Type: | | | |
| Length (ft): | | Special Req. | |
| Height (ft): | | | |
| Kingpin Inset (in): | | | |
| Corner Radius (in): | | | |
| | Restrictions | | |
| Length (ft): | 40 | | |
| Width (in): | 102 | | |
| Height (ft): | 13.5 | | |

Approved by: _____

Date: _____

Note: All sales are F.O.B. designated plant of manufacture.

Price Level: July 1, 2020
 Deal:
 Printed On: 8/28/2020 12:53:35 PM

Date: August 28, 2020
 Quote Number: QUO-698163-N6J4G9



| Sales Code | Std/ Opt | Description | \$ List | Weight |
|-----------------------------------|----------|---|---------|--------|
| Base Model | | | | |
| 0003371 | S | Model 337 The Peterbilt Model 337 is built to take on the big jobs. That's why it's available as a Class 7 truck or tractor with a GVW up to 33,000 lbs. With a full range of suspensions and in an all-wheel-drive configuration, the 337 delivers an ideal match for applications such as wrecker, tanker, beverage delivery, municipal utilities – just about any job you can throw at it. | 95,459 | 10,070 |
| 0091180 | O | Refuse, Scrap, Recycling | 0 | 0 |
| 0093040 | O | Refuse/Landfill Truck which picks up refuse or recycled material from curbside containers in residential areas. Operation typically includes very frequent stops and starts. Unloading can be at transfer station or at landfill (may enter landfill). | 0 | 0 |
| 0095240 | O | Curbside Recycler A lift-equipped truck used to load residential recycling bins into the truck body. Recycling material is removed by the body by hydraulic tilt. | 0 | 0 |
| 0098170 | S | United States Registry Canadian Registry Package Requires Air Conditioning Excise Tax Canada, Speedometer to be KPH Ipo MPH, Daytime Running Lights and Rubber Battery Pad in Bottom of Battery Box. | 0 | 0 |
| Configuration | | | | |
| 0200700 | S | Not Applicable Secondary Manufacturer | 0 | 0 |
| Frame & Equipment | | | | |
| 0514000 | O | 10-3/4" Steel Rails To 354" 10.75x3.5x.375 Dimension, 2,136,000 RBM; Yield Strength: 120,000 psi. Section Modulus: 17.8 cubic inches. Weight: 1.74 lbs/inch pair | 654 | 329 |
| 0612230 | O | Custom Wheelbase or Overhang Engineering approval may be required. | 365 | 0 |
| 0613090 | O | Three-Piece Crossmembers | 593 | 58 |
| 0644020 | O | EOF Square with Steel Crossmember | 147 | 64 |
| 0651090 | S | Omit Rear Mudflaps and Hangers | 0 | 0 |
| Front Axle & Equipment | | | | |
| 1011830 | S | Dana Spicer E1002IL 10,000 lb, 3.5 in. Drop Axle is designed for applications with a gross axle weight rating (GAWR) of 10,000 pounds. The axles have exclusive one-piece forged design knuckle including steer arm, tie rod arm and spindle. This feature helps in greater durability and reduced maintenance. | 0 | 0 |
| 1111180 | S | Taper Leaf Springs, Shocks 10,000 lb | 0 | 0 |

Price Level: July 1, 2020

Deal:

Printed On: 8/28/2020 12:53:35 PM

Date: August 28, 2020

Quote Number: QUO-698163-N6J4G9



| Sales Code | Std/ Opt | Description | \$ List | Weight |
|----------------------------------|----------|--|---------|--------|
| | | Taper leaf springs, shocks 10,000 lbs. designed for a variety of on-highway and vocational trucks. Spring designs that help reduce weight compared to multi-leaf springs. | | |
| 1243040 | S | Power Steering Sheppard HD94 Sheppard HD94 power steering gear is a light weight version of heavy duty line-haul power steering gear. For use with 12,000 to 14,000 lb. axle ratings. | 0 | 0 |
| 1250180 | O | Power Steering Reservoir Frame Mounted The power steering reservoir is a steering system that eases drivability by applying hydraulic pressure to the steering gear. | 0 | 0 |
| 1353545 | O | PHP10 Aluminum PreSet Hubs | 32 | 0 |
| 1380240 | O | Dana Spicer Wide Track IPO Standard Dana Spicer wide track front axles offer added stability and deliver greater turn angles. 71in KPI IPO 69in for E1202, E1322, E1462, D2000F front axles. | 33 | 15 |
| 1380260 | S | Bendix Air Cam Front Drum Brakes 16.5x5 For use with 10,000 lbs to 14,600 lbs steer axles. Includes automatic slack adjusters & outboard mounted brake drums. | 0 | 0 |
| 1391410 | S | Gusseted Cam Brackets, Steer Axle | 0 | 0 |
| Rear Axle & Equipment | | | | |
| 1511440 | O | Meritor RS23-161 23,000 lb Laser factory axle alignment to improve handling & reduce tire wear. Magnetic rear axle oil drain plug captures & holds any metal fragments in drive axle lube to extend service life. Parking brakes on all drive axles for optimal performance. Cognis EMGARD® FE 75W-90 synthetic axle lube provides over 1% fuel economy improvement. Reduces wear & extends maintenance intervals, resulting in increased uptime. Provides improved fluid flow to protect components in extreme cold conditions & withstand the stress from high temperatures, extending component life. | 1,673 | 229 |
| 1616360 | O | PHP10 Aluminum PreSet Hubs | 70 | 0 |
| 1680440 | O | Refuse Service Brakes, Steer And Drive Axles Designed for heavy-duty applications for refuse industry, providing long brake life, safety and performance. | 225 | 0 |
| 1680490 | O | Gusseted Cam Brackets, Drive Axle(s) | 24 | 2 |
| 1680500 | S | SBM Valve Full trucks require a spring brake modulation (SBM) system for emergency braking application. This system requires an SBM valve and a relay valve with spring brakes on the rear axles. The SBM valve allows the foot valve to operate the rear axle spring brakes if a failure exists in the rear air system. | 0 | 0 |
| 1680950 | S | Stability System Not Selected Or Not Available | 0 | 0 |
| 1681337 | S | Single Drive Axle (Model 337) | 0 | 0 |
| 1682430 | S | Anti-Lock Braking System (ABS) 4S4M | 0 | 0 |

Price Level: July 1, 2020

Deal:

Printed On: 8/28/2020 12:53:35 PM

Date: August 28, 2020

Quote Number: QUO-698163-N6J4G9



| Sales Code | Std Opt | Description | List | Weight |
|------------|---------|---|------|--------|
| | | ABS-6. Includes air braking system. | | |
| 1684200 | S | Synthetic Axle Lubricant All Axles Peterbilt heavy duty models include Fuel Efficient Cognis EMGARD FE75W-90 which provides customers performance advantages over current synthetic lubricants with reduced gear wear and extended maintenance intervals, resulting in increased uptime. In addition, the lubricant provides improved fluid flow to protect gears in extreme cold conditions and withstand the stress from high temperatures, extending component life. | 0 | 0 |
| 1687010 | S | Bendix Air Cam Rear Drum Brakes 16.5x7 Bendix Air Cam Rear Drum Brakes to fit all heavy haul, construction, refuse and highway truck and tractor applications. Includes Automatic Slack Adjusters & Outboard Mounted Brake Drums. | 0 | 0 |
| 1705380 | O | Ratio 5.38 Rear Axle | 0 | 0 |
| 1816120 | U | Reyco 79KB Mult Leaf 31,000 lbs. | 559 | 119 |

Engine & Equipment

| | | | | |
|---------|---|---|-------|---|
| 2074306 | O | PACCAR PX-9 300@2000 GOV@2200 860@1300 Productivity (2017 Emissions) Includes alum flywheel housing, cruise control, and J1939 provisions (provides an interface point for the Electronic Service Analysis-ESA and other PACCAR approved diagnostic tools). Chevron Delo LE SAE 10W30 engine oil is specially formulated for new low emissions engines. Magnetic engine oil drain plug captures and holds any metal fragments in engine oil to extend service life. N21320 N205 120...Standard Maximum Speed Limit N21470 P062 NO...Cruise Control Auto Resume (N21480 P068 NO...Auto Engine Brake in Cruise N21450 P026 NO...Gear Down Protection (P026) N21440 P015 YES...Engine Protection Shutdown (N21350 P001 75...Maximum Accelerator Pedal Ve N21370 P059 75...Maximum Cruise Speed (P059) N21590 P230 YES...Enable Hot Ambient Automatic N21530 P233 YES...Enable Impending Shutdown Wa N21540 P234 60...Timer For Impending Shutdown N21460 P046 1400..Max PTO Speed (P046) N21520 P030 5.....Timer Setting (P030) N21570 P031 NO....Idle Shutdown Manual Overrul N21610 P172 40....Low Ambient Temperature Thre N21630 P171 80....High Ambient Temperature Thr N21510 P520 YES...Enable Idle Shutdown Park Br N21430 N201 0.....Reserve Speed Limit Offset (N21410 N202 0.....Maximum Cycle Distance (N202 N21400 N203 252...Reserve Speed Function Reset N21420 N206 10....Maximum Active Distance (N20 N21340 P112 120...Hard Maximum Speed Limit (P1 N21550 P516 100...Engine Load Threshold (P516) N21620 P173 60....Intermediate Ambient Tempera N21330 N207 0.....Expiration Distance (N207) | 1,943 | 0 |
|---------|---|---|-------|---|

Price Level: July 1, 2020

Deal:

Printed On: 8/28/2020 12:53:35 PM

Date: August 28, 2020

Quote Number: QUO-698163-N6J4G9



| Sales Code | Qty | Description | Stk | Weight |
|------------|-----|--|-----|--------|
| | | N21500 N209 0.....Expiration Distance (N209) | | |
| 2091305 | O | Engine Idle Shutdown Timer Enabled | 0 | 0 |
| 2091315 | O | Enable EIST Ambient Temp Overrule | 0 | 0 |
| 2091372 | | Eff EIST NA Expiration Miles | 0 | 0 |
| 2091640 | | Effective VSL Setting NA | 0 | 0 |
| 2092012 | O | Typical Operating Speed 55 MPH | 0 | 0 |
| 2092032 | O | Powertrain Optimized for Performance Best analysis for vehicles used in vocational applications or with heavy GCWRs. | 0 | 0 |
| 2140150 | O | Remote PTO and Throttle Provision 12-pin connector on engine harness. | 17 | 0 |
| 2140200 | S | CARB Engine Idling Compliance PACCAR PX-7, PX-9 and MX, Cummins X15 and ISX diesel engines will include the required factory installed serialized sticker on the drivers door to identify them as meeting the NOx idling standard. | 0 | 0 |
| 2140330 | O | Remote Throttle/PTO Control Switch & Wiring BOC W/ Park Brake | 53 | 0 |
| 2513080 | S | PACCAR 160 Amp Alternator, Brushed PACCAR 160 AMP alternator, brushed producing 160 Amps at road speed and 100 Amps at idle. | 0 | 0 |
| 2521090 | O | Immersion Type Block Heater 110-120V Standard location for 2.1M and 1.9M models is left-hand under cab, Model 520 is in bumper, and for Model 220 it is at the driver step. Plug includes a weather-proof cover that protects the receptacle. This pre-heater keeps the coolant in the engine block from freezing when the engine is not running. | 86 | 2 |
| 2522110 | S | PACCAR 12V Starter, N/A PACCAR MX Engines PACCAR 12-volt electrical system. With centralized power distribution incorporating plug-in style relays. Circuit protection for serviceability, 12-volt light system w/circuit protection circuits number & color coded. | 0 | 0 |
| 2538040 | O | 3.PACCAR Premium 12V Dual Purpose Batt 2190 CCA Threaded stud type terminal. Stranded copper battery cables are double aught (00) or larger to reduce resistance. | 261 | 62 |
| 2539410 | O | Battery Jumper Terminal Mounted Under Hood LH Frame Rail. Not available with PX-7 engines. | 99 | 4 |
| 2621000 | O | 2-Speed Fan Clutch For Frequent Start/Stops A 2-speed fan clutch is ideal for vocational applications where the fan clutch engagement time exceeds 10% of the engine run time. When the fan clutch is disengaged, the fan still rotates at 15-25% of the engine RPM. This fan rotation provides crucial airflow to the engine and draws virtually no horsepower. | 374 | 0 |
| 2723210 | S | 18.7 CFM Air Compressor N/A X15. Furnished on engine. Teflon lined stainless steel braided compressor discharge line. | 0 | 0 |

Price Level: July 1, 2020

Deal:

Printed On: 8/28/2020 12:53:35 PM

Date: August 28, 2020

Quote Number: QUO-698163-N6J4G9



| Sales Code | Std/ Opt | Description | \$ List | Weight |
|-------------------------------------|----------|---|---------|--------|
| 2812210 | O | VGT Exhaust Brake (Variable Geometry Turbo). Provides approximately 90-100 HP of retardation and is part of the turbocharger. | 65 | 0 |
| 2921160 | S | Spin-On Fuel/Water Separator | 0 | 0 |
| 2921210 | S | No Fluid Heat Option for Fuel Filter | 0 | 0 |
| 2921310 | S | No Electric Heat Option for Fuel Filter | 0 | 0 |
| 3114270 | S | High Efficiency Cooling System Cooling module is a combination of steel and aluminum components, with aluminum connections to maximize performance and cooling capability. Silicone radiator & heater hoses enhance value, durability, & reliability. Constant tension band clamps reduce leaks. Chevron Delo Extended Life Coolant (NOAT) extends maintenance intervals reducing maintenance costs. Anti-freeze effective to -30 degrees F helps protect the engine. Low coolant level sensor warns of low coolant condition to prevent engine damage. Radiator Size by Model: 579/367 FEPTO 1325 sq in, 567/365/367: 1440 sq in, 365 FEPTO: 1184 sq in, 389/367 HH: 1669 sq in, 348: 1000 sq in, 520: 1242 sq in. | 0 | 0 |
| 3211120 | S | Radial Seal, Dry Type Air Cleaner, Frontal Air Intake. Molded rubber air intake connections with lined stainless steel clamps seal to prevent contaminants in air intake. | 0 | 0 |
| 3365270 | O | Exhaust Single RH Side of Cab DPF/SCR right-hand Under Cab. | 405 | 29 |
| 3381770 | O | Curved Tip Standpipe(s) | 42 | 0 |
| 3387890 | O | 36" Ht, 5" Dia Chrome, Clear Coat Standpipe(s) | 525 | 4 |
| Transmission & Equipment | | | | |
| 4052110 | O | Allison 3000 RDS-P Transmission, Gen 5 Rugged Duty Series. Includes Rear Transmission Support except on MX engines, Mobil Delvac Automatic Transmission Fluid, and Water-Oil Heat Exchange. Also includes features that monitor the transmission fluid, filter and clutch condition. Will display percent life remaining for the transmission fluid, filter and clutches on the shift selector. This information may be displayed using the Mode and Up and Down buttons. A wrench icon will also be included to indicate when the transmission fluid, filter or clutches need servicing. Suited for vehicles operating on/off highway and/or requiring PTO operation. Forward ratios: 1st-3.49, 2nd-1.86, 3rd-1.41, 4th-1.00, 5th-0.75, 6th-0.65. Reverse ratios: DR-(5.03). | 10,517 | 195 |
| 4210320 | O | 1710 HD Driveline, 2 Midship Bearings | 635 | 100 |
| 4252170 | O | Auto Neutral Activates With Parking Brake Auto Neutral helps improve jobsite safety by reducing the possibility of the truck moving due to throttle application. | 16 | 0 |
| 4252890 | O | Allison FuelSense 2.0 Not Desired | 0 | 0 |

Price Level: July 1, 2020

Deal:

Printed On: 8/28/2020 12:53:35 PM

Date: August 28, 2020

Quote Number: QUO-698163-N6J4G9



| Sales Code | Std/Opt | Description | \$ List | Weight |
|------------------------------------|---------|--|---------|--------|
| 4252940 | O | Allison Neutral At Stop Neutral at Stop features and benefits: Reduces or eliminates the load on the engine when vehicle is stopped, can help lower fuel consumption and CO2 emissions, and is included in FuelSense 2.0 Plus and Max packages only. | 0 | 0 |
| 4256640 | O | Allison 6-Speed Configuration, Close Ratio Gears 3000 Series Transmissions. | 0 | 0 |
| 4256920 | O | Dash Mounted Push Button Shifter Available with Allison transmissions | 626 | 0 |
| Air & Trailer Equipment | | | | |
| 4510320 | S | Bendix AD-1S Air Dryer, Heater Bendix Air Treatment Oil Coalescing filter, extended purge. Collects and removes solid, liquid and vapor contaminants before they enter the air brake system. | 0 | 0 |
| 4520420 | O | Pull Cords All Air Tanks | 7 | 0 |
| 4540420 | S | Nylon Chassis Hose | 0 | 0 |
| 4543320 | S | Steel Painted Air Tanks All air tanks are steel with painted finish except when Code 4543330 Polish Aluminum Air Tanks is also selected (then exposed air tanks outside the frame rails will be polished aluminum). Peterbilt will determine the optimal size and location of required air tanks. Narratives requesting a specific air tank size or location will not be accepted for factory installation. See ECAT to determine number or location of air tanks installed. | 0 | 0 |
| 4611930 | O | Body Connections 5' BOC Junction box contains light and power circuits for body connections located 5' from back-of-cab | 132 | 4 |
| Tires & Wheels | | | | |
| 5061050 | O | FF: BR 14ply 11R22.5 R284 Ecopia | 59 | -4 |
| 5169830 | O | RR: BR 14 PLY 11R22.5 M760 Ecopia Diameter= 42.2 Inches; SLR= 19.6 inches | 120 | 28 |
| 5190004 | O | Code-rear Tire Qty 04 | 0 | 0 |
| 5211990 | S | FF: Accu-Lite Steel Armor 51408PK 22.5X8.25 PHP10-2 hand holes | 0 | 0 |
| 5311990 | S | RR: Accu-Lite Steel Armor 51408PK 22.5X8.25 PHP10-2 hand holes | 0 | 0 |
| 5390004 | O | Code-rear Rim Qty 04 | 0 | 0 |
| Fuel Tanks | | | | |
| 5554070 | O | 26" Aluminum 60 Gallon Fuel Tank LH U/C | 116 | -117 |

Price Level: July 1, 2020

Deal:

Printed On: 8/28/2020 12:53:35 PM

Date: August 28, 2020

Quote Number: QUO-698163-N6J4G9



| Sales Code | Std/ Opt | Description | \$ List | Weight |
|---------------------------------|----------|---|---------|--------|
| | | Includes steps for cab access. Paddle handle filler cap with threadless filler neck. Top draw fuel plumbing reduces chance of introducing air into the fuel system during low fuel level conditions due to the central placement of fuel pickup tube. Wire braid fuel lines increase durability & reduce potential for leaks. | | |
| 5602060 | O | Location LH U/C 60 Gallon | 0 | 0 |
| 5652890 | S | DEF Tank Mounted LH BOC Models 220 and 520 mounted left hand back-of-cab. | 0 | 0 |
| 5652990 | S | DEF To Fuel Ratio 2:1 Or Greater | 0 | 0 |
| 5655019 | O | DEF Tank Small 11.1 Gallon Capacity | -162 | 0 |
| Battery Box & Bumper | | | | |
| 6010780 | O | Aluminum Space Saver Battery Box RH BOC Battery access from side | 217 | -84 |
| 6040550 | S | Aftertreatment Aluminum Non-Slip Cab Entry Aftertreatment right-hand under cab step. DPF/SCR for diesel engines, catalyst for natural gas engines. On Models 579 specifying chassis fairings, the box is aerodynamic. | 0 | 0 |
| 6121180 | S | Steel Styled Aero Bumper Painted Cab Color Two tow points | 0 | 0 |
| Cab & Equipment | | | | |
| 6510110 | S | Alum Cab 108In BBC Metton Hood w/Bright Crown Includes view window RH door and convex mirror over RH door. | 0 | 0 |
| 6540160 | O | Thermal Insulation Package in Cab Includes thick, closed-cell foam in floor, special mylar-faced foam in walls and roof structure. | 19 | 2 |
| 6911700 | S | National Driver Seat | 0 | 0 |
| 6923160 | S | (2) Person Passenger Seat | 0 | 0 |
| 6930500 | O | Drivers Armrest - RH Only | 40 | 2 |
| 6939400 | O | Air Ride Driver | 198 | 0 |
| 6939420 | S | High Back Driver | 0 | 0 |
| 6939470 | S | Vinyl Driver | 0 | 0 |
| 6939510 | S | Non-Air Ride Passenger | 0 | 0 |
| 6939540 | S | Low Back Passenger | 0 | 0 |
| 6939570 | S | Vinyl Passenger | 0 | 0 |

Price Level: July 1, 2020

Deal:

Printed On: 8/28/2020 12:53:35 PM

Date: August 28, 2020

Quote Number: QUO-698163-N6J4G9



| Sales Code | Std. Opt. | Description | Price | Weight |
|------------|-----------|---|-------|--------|
| 7001520 | O | Adjustable Steering Column - Tilt/Telescope | 95 | 11 |
| 7001620 | S | Steering Wheel With Peterbilt Logo Steering Wheel with embossed Peterbilt logo over horn button. | 0 | 0 |
| 7036120 | S | Interior Gray/Black Includes rugged charcoal instrument panels, glare-resistant gray dash, black bezels on gauges, (2) power ports, monochromatic molded door pads with durable in-mold color, gray molded back wall, 18 inch 4-spoke soft-touch steering wheel, soft-touch steering column cover, power lift passenger window, extruded rubber floor covering, header-mounted dome light, foot well lighting, integrated "dead pedal", (4) inside entry grab handles, (2) inside sunvisors, (2) coat hooks, (2) cup holders and map bin in dash. | 0 | 0 |
| 7210430 | O | Extended Rear Window ipo Std Window-Day Cab The extended rear window protrudes two inches more than the standard conventional rear cab window. Take this into consideration when determining your loadspace. | 68 | 18 |
| 7210540 | S | Day Cab Rear Window Day cab rear window flush to back of cab. | 0 | 0 |
| 7230060 | S | 1-Piece Curved Windshield | 0 | 0 |
| 7322010 | S | Combo Fresh Air Heater/Air Conditioner With radiator mounted condenser, dedicated side window defrosters, BI-Level Heater/Defroster Controls, 54,500 BTU/HR, and silicone heater hoses. | 0 | 0 |
| 7330700 | O | Peterbilt Comfort Control - Cab | 21 | 6 |
| 7410040 | O | Outside Sunvisor - Stainless Steel Not available with 2.1M high roof sleeper. | 222 | 4 |
| 7511010 | O | Stainless Steel Mirrors 7 x 16 with Heat Element | 70 | 2 |
| 7560850 | O | (2) Convex 8 Inch SSTL Mirrors Center mounted under mirror bracket. If rear view mirrors are heated, the convex mirrors will be heated. Option includes dual door stops. | 266 | 4 |
| 7564110 | S | Power Package Includes power door locks and power windows. | 0 | 0 |
| 7610020 | O | (1) Air Horn 15" Painted Mounted under cab. | 178 | 8 |
| 7722120 | O | ConcertClass, AM/FM, Weatherband, 3.5 Aux | 317 | 10 |
| 7725710 | O | Standard Speaker Package For Cab (2) Speakers | 116 | 4 |
| 7728040 | O | Bluetooth Phone and Audio | 54 | 0 |
| 7728050 | O | USB Port | 54 | 0 |
| 7850210 | O | Plug-In Auto Reset Circuit Breaker in place of fuses in junction box. | 40 | 0 |
| 7851480 | S | Peterbilt Electric Windshield Wipers | 0 | 0 |

Price Level: July 1, 2020

Deal:

Printed On: 8/28/2020 12:53:35 PM

Date: August 28, 2020

Quote Number: QUO-698163-N6J4G9



| Sales Code | Std/Opt | Description | \$ List | Weight |
|--------------|---------|--|---------|--------|
| | | With Intermittent Feature. | | |
| 7900090 | O | Triangle Reflector Kit, Shlp Loose Florescent triangle emergency road flares are designed to meet and exceed all DOT standards. | 17 | 13 |
| 7900270 | O | Fire Extinguisher, Cab Mounted Hazmat approved UL listed/rated ABC | 54 | 8 |
| 7901130 | O | Backup Alarm (107 DB) | 51 | 3 |
| 8011400 | O | Main Transmission Oil Temperature Gauge Located in Driver Information Display | 18 | 0 |
| 8021015 | O | Air Application Gauge Located in Driver Information Display | 0 | 0 |
| 8021380 | S | Air Restriction Indicator Mounted on air cleaner, intake piping, or firewall | 0 | 0 |
| 8071870 | S | Main Instrumentation Panel, Graphics Display Includes speedometer with trip odometer, tachometer with hourmeter and outside air temperature display, voltmeter, engine oil pressure, engine coolant temperature, fuel level, primary and secondary air pressure gauges. Includes standard warning light package: high water temperature, low oil pressure, and low air pressure warning lights with audible alarms, high beam, turn signal, low fuel, parking brake, and ice warning indicators; seat belt reminder; rocker switches with long-life LED indicators; multi-function turn stalk with flash-to-pass feature (night mode flashes headlights and marker lights; day mode flashes headlights only), intermittent windshield wiper and headlamp beam control. Hydraulic braked trucks do not include air pressure gauges. | 0 | 0 |
| 8072560 | O | (1) Additional Dash Switch With Wiring (1) additional dash switch with wiring. Spare 1 and 2 share 15 amp fuse, spares 3, 4, and 5 share 15 amp fuse. Availability subject to dash space. | 47 | 0 |
| 8111110 | S | Headlights Composite Fender Mounted Integral park, turn, and side marker | 0 | 0 |
| 8120980 | S | (5) Marker Lights, Aero LED | 0 | 0 |
| 8133470 | O | Switch & Wiring for F/O Beacon/Strobe Switch and wiring for furnished by owner beacon / strobe, 10' coiled wire back-of-cab / back-of-sleeper, at rear sill. | 67 | 2 |
| 8134070 | O | (2) Additional Dome/Reading Lights, Ceiling Mtd | 49 | 0 |
| 8140120 | S | Incandescent Square Stop/Turn/Tail/Backup Left-hand / right-hand square end of frame or dropped a-brace | 0 | 0 |
| 8140490 | O | Additional LED Round Turn Signal Mirror mounted | 154 | 2 |
| Paint | | | | |
| 8500710 | O | Standard Paint Color Selection | -200 | 0 |
| 8530770 | S | (1) Color Axalta Two Stage - Cab/Hood Base Coat/Clear Coat | 0 | 0 |

Price Level: July 1, 2020

Deal:

Printed On: 8/28/2020 12:53:35 PM

Date: August 28, 2020

Quote Number: QUO-698163-N6J4G9



| Sales Code | Std Opt | Description | \$ List | Weight |
|------------|---------|-------------------------------|---------|--------|
| | | N85020 A - L0006EY WHITE | | |
| | | N85700 BUMPER L0006EY WHITE | | |
| | | N85500 CAB ROOF L0006EY WHITE | | |
| | | N85300 FENDER L0006EY WHITE | | |
| | | N85200 FRAME L0001EA BLACK | | |
| | | N85400 HOOD TOP L0006EY WHITE | | |

Shipping Destination

Options Not Subject To Discount

| | | | | |
|---------|---|--|---|---|
| 9400091 | S | Peterbilt Class 7 Standard Coverage 1 year/Unlimited Miles/km | 0 | 0 |
| 9400094 | S | PACCAR PX-9 Standard Coverage 2 yrs/250,000 mi (402,336 km)/6,250 hrs | 0 | 0 |

Miscellaneous

| | | | | |
|---------|---|--|---|---|
| 9409800 | S | 2017 EPA Emissions Engine Warranty Only | 0 | 0 |
| 9409869 | O | Presentation Created With SmartSpec | 0 | 0 |

Promotions

Order Comments

| | |
|---|-----------|
| Total List Price (WO Freight & Warranty & Surcharges) | \$118,002 |
| Marketing and Service Support Fee | \$550 |
| Prepaid Freight | \$2,450 |
| Total Surcharge/Options Not Subject To Discount | \$0 |
| Total Weight | 11,208 |

Prices and Specifications Subject to Change Without Notice.

Unpublished options may require review/approval.
Dimensional and performance data for unpublished options may vary from that displayed in CRM.

PRICING DISCLAIMER

While we make every effort to maintain the web site to preserve pricing accuracy, prices are subject to change without notice. Although the information in this price list is presented in good faith and believed to be correct at the time of printing, we make no representations or warranties as to the completeness or accuracy of this information. We reserve the right to change, delete or otherwise modify the pricing information which is

Price Level: July 1, 2020

Deal:

Printed On: 8/28/2020 12:53:35 PM

Date: August 28, 2020

Quote Number: QUO-698163-N6J4G9



represented herein without any prior notice. We carefully check pricing specifications, but occasionally errors can occur, therefore we reserve the right to change such prices without notice. We disclaim all liability for any errors or omissions in the materials. In no event will we be responsible for any damages of any nature whatsoever from the reliance upon information from these materials. Please check your order prebills to confirm your pricing information

Price Level: July 1, 2020

Deal:

Printed On: 8/28/2020 12:53:35 PM

Date: August 28, 2020

Quote Number: QUO-698163-N6J4G9

Chassis Number(s): 758270

**PETERBILT MOTORS COMPANY
Medium Duty Warranty Schedule
United States
VEHICLE**

THIS WARRANTY APPLIES ONLY TO ORIGINAL FACTORY EQUIPMENT, in accordance with the terms and limitations in the Warranty Agreement. This warranty does not apply to the Engine or Emission related equipment which is warranted separately by Peterbilt. Peterbilt Motors Company will warrant claims for defective material or workmanship within the following maximum limits in time or mileage, whichever shall occur first. The defective condition must be brought to the attention of an authorized U.S. or Canadian Peterbilt Dealer within 30 days of discovery.

| | MONTHS | MILES |
|--|--------|-----------|
| BASIC VEHICLE This coverage applies to the basic highway vehicle, except for additional coverage and warranty exclusions below. | 12 | Unlimited |
| MAJOR COMPONENTS Eaton, Meritor & Dana Spicer front axle, beam, spindles, kingpin & kingpin bushings. Eaton, Meritor & Dana Spicer rear axle, differential assembly, axle shafts & axle housing. Manual transmissions, gears, shafts, case & bell housing. Eaton auto shift. Eaton and Meritor brakes, brackets, cam shafts, spiders and slack adjusters (excludes Air Disc Brakes). Structural components of the cab and hood. Sheppard and TRW steering gears. | 24 | Unlimited |
| FRAME, CAB STRUCTURE AND CAB CORROSION Frame rails, gussets, cross-members and A-Braces. Cab and hood perforation caused by corrosion from within. This warranty does not apply to corrosion caused by damage to a cab panel or to finish paint. | 36 | Unlimited |
| PACCAR BRANDED BATTERIES | 12 | Unlimited |
| GASKETS AND WHEEL SEALS | 12 | 50,000 |
| ALCOA WHEELS - Coverage is 100% parts only, for 5 years from date of manufacture. | 60 | Unlimited |
| CAB & HOOD PAINT | 12 | 100,000 |
| FRAME PAINT - Black Only | 12 | 100,000 |
| FRAME PAINT - All Colors Other Than Black | 6 | 50,000 |
| FRAME PAINT - Logger Mixer, Dump, Refuse, Oil field & Construction applications | 3 | 25,000 |
| SEVERE SERVICE VEHICLE - All Peterbilt installed components except as excluded below. Severe Service vehicles are those operated 10% or more on class C or D roads. | 12 | 50,000 |

Warranty Exclusions

The following components are warranted directly to you by their respective manufacturer and are NOT warranted by Peterbilt Motors Company: Automatic Transmission, Fifth Wheel, Tires, Tubes, Pintle hooks, Hitch, Wheels and Batteries not listed above.

PETERBILT does not warrant Anti freeze, Lubricants, Bulbs, Fuses, Filters, Mud-flaps, Winter Front, Wiper Nozzles or Wiper Blades. Trade accessories such as Fire Extinguisher, Chains, Emergency Kits and Tools are not warranted.

PETERBILT is not responsible for storage deterioration, wear and changes in adjustment resulting from normal service. This includes Brake and Clutch Linings, Belts, Wheel Balance and Axle Alignment or Upholstery.

PETERBILT does not warrant metallic chassis (frame) paint. Peterbilt is not responsible for paint chipping or fading, peeling from frame bolts relating to maintenance or paint peeling from road chemical damage.

Damage due to accident, misuse, negligence, improper or insufficient maintenance, or unauthorized modification is not warranted. Failure of replacement parts used to repair above conditions is not warrantable.

Vibrations, squeaks, loose fittings and hose leaks, unusual noises, rattles, loose nuts/bolts and hose and electrical connections can develop during the shakedown trips of the vehicle. Up to 20,000 miles, but no later than 90 days after date of delivery, the necessary adjustments will be made without charge. Such developments after this period are usually the result of use and are not warrantable items.

PETERBILT is not responsible for towing, downtime expenses, loss of income, lodging or meal expenses associated with any vehicle warrantable failure.

PETERBILT is not responsible for damage resulting from engine horsepower/torque upgrades.

Chassis Number(s): 758270

PETERBILT MOTORS COMPANY
Medium Duty Warranty Schedule
United States
ENGINE

Engine Serial Number(s)

46772118

PX7
PACCAR PX-6 Engine

Basic Engine Coverage - (All applications except fire apparatus truck) - Twenty-four (24) months - no mileage limitation.

Fire Apparatus Truck Applications - 60 Months or 100,000 miles, whichever occurs first. (Owner is responsible for a US\$100 deductible per each service visit in the 3rd, 4th and 5th years of warranty.)

PACCAR PX-8 Engine *PX9*

Basic Engine Coverage - (All applications except fire apparatus truck) - Twenty-four (24) months or 250,000 miles or 6,250 hours, whichever occurs first.

Fire Apparatus Truck Applications - 60 Months or 100,000 miles, whichever occurs first. (Owner is responsible for a US\$100 deductible per each service visit in the 3rd, 4th and 5th years of warranty.)

In addition to paying for the repair of the Engine, PETERBILT will pay for the lubricating oil, antifreeze, filter elements, belts, hoses and other maintenance items that are not reusable due to the Warrantable Failure. PETERBILT will pay for reasonable labor costs for Engine removal and reinstallation when necessary to repair a Warrantable Failure.

PETERBILT will pay reasonable costs for towing a vehicle disabled by a Warrantable Failure to the nearest authorized repair location for the first year from the date of delivery of the Engine to the first purchaser or the duration of the warranty, whichever occurs first. In lieu of the towing expense, PETERBILT will pay reasonable costs for mechanics to travel to and from the location of the vehicle, including meals, mileage, and lodging when the engine repair is performed at the site of the failure.

Owner's Responsibility

Owner is responsible for the operation and maintenance of the Engine as specified in the applicable PACCAR Operators Manual. Owner is also responsible for providing proof that all recommended maintenance has been performed. Before the expiration of the applicable warranty, Owner must notify either a PETERBILT authorized engine dealer, a PACCAR authorized engine repair facility or an authorized Cummins Distributor of any Warrantable Failure and make the Engine available for repair by such facility. Except for Engines disabled by a Warrantable Failure during the first year from the date of delivery of the Engine to the first purchaser or the duration of the warranty, whichever occurs first, Owner must also deliver the Engine to the authorized repair facility. Locations in the United States and Canada of authorized PETERBILT engine dealers and authorized Cummins Distributors are listed on www.PETERBILT.com.

Owner is responsible for the cost of lubricating oil, antifreeze, filter elements and other maintenance items provided during warranty repairs unless such items are not reusable due to the Warrantable Failure.

Owner is responsible for communication expenses, meals, lodging and similar costs incurred as a result of a Warrantable Failure. Owner is responsible for non-Engine repairs and for "downtime" expenses, cargo damage, fines, all applicable taxes, all business costs and other losses resulting from a Warrantable Failure.

Limitations

PETERBILT is not responsible for failures or damage resulting from what PETERBILT determines to be abuse or neglect, including but not limited to: operation without adequate coolants or lubricants; over-fueling; over-speeding; lack of maintenance of lubricating, cooling or intake systems; improper storage, starting, warm-up, run-in or shutdown practices; unauthorized modifications of the Engine. PETERBILT is also not responsible for failures caused by incorrect oil or fuel or by water, dirt or other contaminants in the fuel or oil.

This warranty does not apply to accessories supplied by PETERBILT which are covered by the Peterbilt Motors Company.

Failures resulting in excessive oil consumption are covered for the duration of the coverage or 100,000 miles or 6,250 hours from the date of delivery of the Engine to the first user, whichever of the three occurs first. Before a claim for excessive oil consumption will be considered, Owner must submit adequate documentation to show that consumption exceeds PETERBILT published standards.

Failures of belts and hoses supplied by PETERBILT are covered during the first year from the date of delivery of the Engine to the first purchaser or the duration of the warranty, whichever occurs first. Parts used to repair a Warrantable Failure may be new parts, approved rebuilt parts, or repaired parts. PETERBILT is not responsible for failures resulting from the use of parts not approved by PETERBILT. A new or approved rebuilt part used to repair a Warrantable Failure assumes the identity of the part it replaced and is entitled to the remaining coverage hereunder.

PETERBILT reserves the right to Interrogate Electronic Control Module (ECM) data for purposes of failure analysis.
PETERBILT DOES NOT COVER WEAR OR WEAROUT OF COVERED PARTS.



HEIL ENVIRONMENTAL WARRANTY STATEMENT

The Heil Co. d/b/a Heil Environmental ("Heil") warrants its waste collection equipment to be free from defects in material and workmanship under normal single-shift use for a period of Twelve (12) months or 2000 hours of operation (whichever comes first) from the date of equipment In-Service or during the period of coverage offered by an extended warranty program, when operated in accordance with its *Operator's Manual* and proper service and maintenance as described in *Heil Service Bulletins* and *Parts & Service Manuals* are performed. The standard or extended equipment warranty is not transferable except for sales demonstration units.

This warranty is expressly limited to the repair or replacement of any component or part thereof, of any such collection body manufactured by Heil that is proven to Heil's satisfaction to have been defective in material or workmanship. Such components or parts shall be repaired or replaced at Heil's option without cost to the original purchaser for parts and labor provided such unit is returned to an authorized Heil Dealer for replacement or repair. The repair or replacement must be made during the standard or extended warranty coverage period.

Before any warranty can be allowed on new equipment, a validated warranty registration form must be on file with Heil's Customer Service Department within sixty (60) days of the equipment's In-Service date. Wear items are excluded from warranty coverage.

All OEM service parts sold by Heil have a six (6) month warranty from the date of purchase. Aftermarket parts purchased from Heil are supported by a 90-day warranty. The parts warranty covers parts only, providing that factory inspection reveals a defect in material or workmanship. Labor, troubleshooting, equipment downtime, etc. is not covered under the parts warranty policy.

HEIL MAKES NO OTHER WARRANTY, EXPRESSED OR IMPLIED, AND MAKES NO WARRANTY OF MERCHANTABILITY OR OF FITNESS FOR ANY PARTICULAR PURPOSE. HEIL DOES NOT ASSUME ANY LIABILITY OR ACCEPT CLAIMS FOR LOSS OF PROFITS, PRODUCT DOWN TIME OR ANY OTHER DIRECT, INCIDENTAL OR INDIRECT CONSEQUENTIAL LOSSES, COSTS, DAMAGES, OR DELAYS.

Any improper use, operation beyond rated equipment or component capacity, substitution of parts that are not Heil approved, or any alteration or repair by others in such a manner as in Heil's sole judgment affect the product operation or integrity shall void the warranty. Other than the extension of the standard warranty period purchased under a supplemental *Heil Extended Warranty Program*, no employee or representative is authorized to modify this warranty in any way nor shall any other warranties be granted. No dealer-supplied warranty program is endorsed or supported by Heil. Heil retains the right to modify its factory warranty program at any time.

BID SHEET
One (1) 20-yard rear load refuse truck

BRAND AND MODEL: Peterbilt 337 and Loadmaster Legacy 20yd

YEAR: Peterbilt - 2021 Loadmaster - 2020

APPROXIMATE DELIVERY DATE: 90 days

WARRANTY: Peterbilt - standard 1 year Loadmaster - 1 year

3 years cylinders

ALL OPTIONS SHALL REFLECT THOSE COSTS IN ADDITION TO THE BASE BID

DELIVERED F.O.B. TO CITY OF RUSSELL, 333 E. 9th St.

| | OUT-RIGHT PRICE | TRADE-IN CREDIT | TOTAL |
|--|-------------------|-----------------|-----------------------------------|
| BASE BID- (LIST ITEM HERE) | \$ <u>153,823</u> | <\$_XXX_> | \$ <u>153,823</u> |
| OPTION #1 - 2 year or 2,000 hour warranty | | | \$ <u>SEE warranty papers</u> |
| TOTAL BID | | | \$ <u>153,823</u> |

REPRESENTATIVE Eric Kelderman

COMPANY The Larson Group dba Truck Component Services

ADDRESS 4044 Coyote Dr. Joplin, MO 64804

TELEPHONE NUMBER 816-661-3286 DATE 9/2/20

COMMENTS Extended Warranties - Let's talk - several
different options on Peterbilt extended warranties.



Truck Component Services

403 Evergreen Road
Strafford, MO 65757
417-829-6700



City of Russell, KS

Bid for one (1) 20yd rear load refuse truck

***Additional options and prices not currently included:**

1. *Dual* clean-out doors on sides of the body that can be opened to release liquids as well as ease in cleaning of behind the blade without climbing into the body. **\$890**
2. Hydraulic roof line cover for the top of the body – helps protect tree branches etc. from catching on any hydraulic lines. **\$400**
3. Upgraded three camera Roscoe DVR recording camera system. Provides safety for both the driver and for the city. **\$1,513**
4. Tool holders on side of the tailgate **\$195**
5. Remote grease zerks for “grease from the ground” access for safety and to encourage maintenance **\$350**
6. Container bumper bar which prohibits containers from falling into the hopper while dumping. **\$200**

Truck Component Services
403 E. Evergreen Rd.
Strafford, MO 65757

www.truckcs.com

Refuse Body

Its the intent of these specification to describe the min. requirements for a refuse collection body of a rear load design.

1. Application

- a. Features standard to this unit will be furnished by the successful bidder. Body shall conform in strength, quality of material and workmanship to that provided by the best engineering and manufacturing practice of the industry.
- b. All equipment shall be of the newest design, assembled and ready for operation at the time of delivery.
- c. Bidder shall attach a statement that the unit meets or exceeds these specifications and/or list any exceptions fully and accurately.

Yes

2. General

- a. Refuse body will have a capacity of 20 yards.
- b. Packer body will be able of packing 900 pounds per cubic yard of dry commercial and residential refuse.
- c. Packer body must meet all applicable ANSI Z245.1 safety standards.
- d. PTO is to be of "Hot Shift" design.
- e. Hydraulic kick bar device to lift and dump 3 cubic yard commercial containers, including trunnion locks to lock containers into position along with associated hydraulic components.
- f. (2) Perkins cart tippers. Tippers must tuck away when not in use, and clear the kick bar in all positions.

Yes

3. Body construction

- a. Body shall be of all welded construction.
- b. All pivot points shall be provided with grease zerks.
- c. The sides of the body shall be constructed of 10 gauge, 80,000 psi. steel.
- d. The roof of the body shall be constructed of 10 gauge, 80,000 psi. steel.
- e. The floor of the body shall be constructed of 10 gauge, 80,000 psi. steel.
- f. A side access door shall be located on the left (street) side of the body. The door should be approximately 30" X 30" that allows for the operator to access eject controls and tailgate lift controls w/out door being open.
- g. No hydraulic cylinders, valves or any hydraulic components shall come into contact with refuse packed into body.

YES/NO
YES/NO

YES/NO

YES/NO

YES/NO

YES/NO

YES/NO

4. Body dimensions

- a. The outside width of the body shall not exceed 102"
- b. The overall length of the body including tailgate shall not exceed 234".
- c. The overall height of the body above frame shall not exceed 96".

YES/NO

YES/NO

YES/NO

249"

Refuse Body

Its the intent of these specification to describe the min. requirements for a refuse collection body of a rear load design.

5. Hopper

- a. The hopper capacity shall not be less then 3.0 cubic yards. YES NO
- b. The hopper floor shall be constructed of a minimum of 3/16", 100,000 psi steel. YES NO
- c. The hopper sides shall be constricted of a minimum of 3/16", 50,000 psi steel. YES NO
- d. The hopper opening width shall be shall be a minimum of 84". YES NO 80"
- e. The hopper opening height shall be a minimum of 62". YES NO 60"
- f. The hopper depth shall be a minimum of 16" from top of load sill. YES NO
- g. The hopper load sill height is no greater than the chassis frame height. YES NO
- h. The hopper shall be equipped with an 1 1/2" drain plug. YES NO

6. Tailgate

- a. The tailgate shall be raised by two (2) 3 1/2" bore cylinders mounted on the outside of the tailgate. YES NO
- b. The two (2) lift cylinders must be equipped with flow restrictors to prevent sudden decent. YES NO
- c. The tailgate shall be equipped with a rubber seal to provide a water tight seal between the body and tailgate. The seal must extend a minimum of 36" up the sides. YES NO
- d. The tailgate shall be constructed of 10 gauge, 80,000 psi. steel. YES NO
- e. Bolt on riding steps shall be provided on each side, constructed of grip strut. Each step shall have two (2) 1" diameter grab handles. YES NO

7. Packer

- a. The packer cycle time shall not exceed 23 seconds with a reload time of 8 seconds. YES NO
- b. The packer face plate thickness shall be 3/16", 50,000 psi. steel. YES NO
- c. The packer face plate compacts material into the body against the ejector panel and the roof of the body, not the front of the hopper. YES NO
- d. The packer shall be capable of packing 900 pounds per cubic yard of dry commercial and residential refuse. YES NO

8. Ejector

- a. The load shall be ejected by a double acting, telescopic hydraulic cylinder that shall extends and retracts the ejector panel the full length of the body without the use of clamp bars or related hardware. YES NO

Refuse Body

Its the intent of these specification to describe the min. requirements for a refuse collection body of a rear load design.

- b. The ejector panel will travel on friction reducing composite material that can be easily replaced without removing the panel from the body. YES/NO
- c. No part of the panel shall protrude into the hopper when its in its rear most position. YES/NO
- d. The ejector panel shall have a 10 gauge hi-tensile steel face. YES/NO
- e. The ejector panel shall hold pressure against the compacted material and must automatically "drift" forward by a hydraulic load control valve with out any operator assistance. YES/NO

9. Hydraulics

- a. The hydraulic system shall be designed for easy maintenance. YES/NO
- b. The hydraulic pump shall provide a minimum of 30 GPM. At 1000RPM. YES/NO
- c. The hydraulic system shall incorporate an adjustable main relief valve. YES/NO
- d. The hydraulic reservoir shall have a minimum capacity of 30 gallons of oil. YES/NO
- e. The hydraulic reservoir shall be equipped with a filler/breather cap, sight glass, clean out cover, 100 micron suction filter, magnetic tank drain plug and a shut off valve on the suction side. YES/NO
- f. The hydraulic reservoir shall be mounted inside the body. YES/NO
- g. A replaceable 10 micron filter with a bypass valve and visible sight indicator shall be incorporated in the hydraulic system. YES/NO
- h. All multi spool circuit valves shall be of sectional construction, to allow replacement of defective valve with out replacing the entire valve assembly. YES/NO
- i. All hydraulic hoses are to be SAE. Approved construction. All hoses shall have a burst pressure four (4) times greater than the working pressure. YES/NO
- j. Hydraulic tubing is used where flexible hose is not needed. YES/NO
- k. Hydraulic hoses and tubing shall be secured by clamps as required to prevent damage from abrasion and vibration. YES/NO
- l. All hydraulic assemblies must be located so at no time or load condition it becomes necessary to remove the load to service or repair these components. YES/NO
- m. PTO is to be of "hot shift" design. YES/NO

10. Controls

- a. Controls for the packer are to be located on the right (curb) side at the rear of the tailgate. These controls must have the capacity to start, stop and reverse the packing mechanism. YES/NO

Refuse Body

Its the intent of these specification to describe the min. requirements for a refuse collection body of a rear load design.

- b. The tailgate lift and ejector controls shall be located on the left (street) side, located at the front inside the body. These controls shall be accessed through an opening located in the access door. Controls shall not come into contact with refuse and are protected from the outside elements. YES/NO
- c. Two (2) throttle advance switches shall be provided. One must be located at the right (curb) side near the packing controls. The second switch must be located at the front left (street) side of the body within easy reach of the tailgate and eject controls. This switch may be accessed from the outside of the body. YES/NO
- d. PTO pump controls are to be located in the cab. YES/NO
- e. The two (2) cart tipper controls shall be mounted a minimum of 44" from ground level. Each control shall be mounted on the corresponding side of the tailgate as the tipper itself. YES/NO
- f. One (1) single control lever for the hydraulic kick bar shall be mounted on the right (curb) side of the tailgate. This control shall be mounted a minimum of 44" from ground level. YES/NO

11. Electrical

- a. All electrical connectors shall be of weather tight design. (example. Weather pak or Deutsch) YES/NO
- b. All electrical wiring shall be color coded or labeled. YES/NO
- c. All electrical wired shall be in a braided harness or a loom. YES/NO
- d. All circuits shall be protected by a circuit breaker or fuse. YES/NO
- e. All body lights shall conform to FMVSS#108 regulations. YES/NO
- f. An addition set of stop, tail and turn signal lights shall be mounted above the hopper on a light bar. YES/NO
- g. Two (2) white working lights shall be mounted on the upper half of the tailgate, these lights must be capable of illuminating the hopper. These lights shall be activated from inside the cab. YES/NO
- h. Four (4) corner (LED) strobe lights shall be provided. YES/NO
- i. All lights must be of sealed design, recessed and gromet mounted. The working lights and tag light is exempt. YES/NO
- j. A rear vision camera system shall be provided. The monitor shall be mounted in the cab within easy view of the driver. YES/NO
- k. A backup alarm shall be provided. YES/NO
- l. Two (2) push button switches that alert the driver shall be provided. One mounted on each side of the tailgate. YES/NO
- m. A PTO "kill" switch shall be provided near the packing controls on the right (curb) side of the tailgate. YES/NO

Refuse Body

Its the intent of these specification to describe the min. requirements for a refuse collection body of a rear load design.

- 12. **Paint**
 - n. An in cab light and buzzer shall alert the driver when the tailgate is ajar. YES NO
 - a. All welding slag shall be removed and any rough areas shall be smoothed prior to painting. YES NO
 - b. The entire body shall be properly cleaned and conditioned prior to painting. YES NO
 - c. A minimum of one (1) coat of primer with a rust inhibitor shall be applied to the body prior to painting. YES NO
 - d. A minimum of one (1) coat of white paint shall be applied to the body. Paint shall match the color of cab and provide a high gloss finish. YES NO

- 13. **Additional Accessories and requirements**
 - a. A hydraulic kick bar to lift and dump 3 yard commercial containers shall be provided. This includes all accessories to lock containers in place. YES NO
 - b. Two (2) Perkins rotary cart tippers shall be provided. YES NO
 - c. The cart tippers shall be of tuck away design and clear the hydraulic kick bar in any and all positions. YES NO
 - d. The overall height of combined unit (body mounted to chassis) shall not exceed 11'8" at it highest point. 137.5" YES NO
 - e. One (1) 10 pound fire extinguisher shall be mounted securely on the body and easily accessible to riders. YES NO
 - f. Mud flaps shall be provided ahead and behind the rear axle. YES NO
 - g. A complete Operation Manual and a Service Manual shall be provided. YES NO

Cab and Chassis

1. Application
 - a. The chassis shall be capable of carrying the net weight of a 20 yard refuse body, plus the weight of the refuse to be collected. Yes
 - b. The chassis shall be designed to accommodate the refuse body that is used daily for the removal of both commercial and residential refuse. Yes
 - c. The chassis shall be capable of both a minimum of 55 mph. speeds and frequent starts and stops. Yes

2. Model
 - a. The base chassis model shall be a Peterbilt model 337. YES/NO
 - b. The equipment furnished under these specifications shall be new, 2020 or newest model available. YES/NO *2021 model*
 - c. The vehicle shall come complete with all accessory equipment including the operation and service manuals. YES/NO

3. Axles and equipment
 - a. The front axle shall be rated at 10,000 lbs. YES/NO
 - b. The front axle shall have tapered leaf springs with 10,000 lbs. shocks. YES/NO
 - c. The rear axle shall be rated at 23,000 lbs. YES/NO
 - d. The rear axle shall be of multi leaf design rated at 30,000 lbs. YES/NO
 - e. The vehicle shall have a gross combined weight of 33,000 lbs. YES/NO

4. Engine
 - a. The vehicle shall come with a PACCAR PX9 engine. YES/NO
 - b. The vehicle shall have engine protection shutdown. YES/NO
 - c. The engine shall have a PACCAR 160 amp alternator. YES/NO
 - d. The engine shall have a immersion style block heater 110-120v. YES/NO
 - e. The engine shall have a 2-speed fan clutch. YES/NO
 - f. The engine shall have a VGT exhaust brake. YES/NO
 - g. The engine shall have a spin-on fuel/water separator. YES/NO
 - h. The engine shall have a high efficient cooling system with ELC rated at -30 degrees Fahrenheit. YES/NO
 - i. The vehicle shall have a single right hand side exhaust. YES/NO

5. Transmission and equipment
 - a. Vehicle shall come with an Allison 3000 series RDS-P transmission. YES/NO *Allison 3500 RDS*
 - b. The Allison transmission shall have a six speed configuration. YES/NO
 - c. The vehicle shall have a dash mounted push button shifter. YES/NO

6. Fuel tanks
 - a. The vehicle shall have a minimum of a 60 gallon fuel tank located on the left hand side. YES/NO

7. Cab and equipment
 - a. The vehicle shall come with an 108" aluminum cab. YES/NO
 - b. The cab shall come with the thermal insulation package. YES/NO

Cab and Chassis

- c. The drivers seat shall be of high back, air ride, vinyl design. YES/NO
- d. The two (2) person passenger seat shall be of low back, non-air ride, vinyl design. YES/NO
- e. The steering column shall be capable of both tilt and telescoping. YES/NO
- f. The interior shall be grey/black in color. YES/NO
- e. The cab shall be of day cab design. YES/NO
- f. The cab shall come with a combination of both fresh air heater and air conditioning. YES/NO
- g. The vehicle shall come with the Peterbilt Comfort Control Cab. YES/NO
- h. The cab shall come with AM/FM radio with standard two (2) speaker package. YES/NO

Exception to bid Specifications

Line #

Explanation

4b

Overall length is 249" not 234"

5d

Hopper width is 80" not 84"

5e

Hopper opening height is 60" not 62"

5a

Allison transmission is a 3500 RDS not
3000 RDS



Mid-Compaction Rear Loader

The **Legacy** and **Legacy-S** models have a compaction rate of 800 to 900 pounds per cubic yard. A lighter Loadmaster body on a single rear axle chassis with the pedigree of reliability our customers love. Proudly made in the USA.



906.563.9226



www.loadmaster.org



Lighter Body

Mid-Compaction, Light body for single rear axle chassis. Built with 8 gauge body sides and 7 gauge body floor. Loadmaster reliability and quality available in sizes from 11-25 cubic yards.

Body Access Door

Maintenance is important, we incorporated a large body access door and ladder allowing our customers to safely maintain the hydraulic components behind the ejector at the front of the body.

Dual Clean Out Door Option

One of our most popular options for our rear loaders. Making it easier to clean out behind the ejector and the front of the body. Sealed to prevent liquid leaking from the body.



906.563.9226

LED Lights Standard

Every Loadmaster is equipped with LED lights by default. LED technology provides enhanced visibility and superior longevity in a small package.

Super Tough Blades

Loadmaster blades are built to last even on the toughest routes. Sweep blade equipped with a 3/16" T-1 face panel, slide blade equipped with a 7 gauge high tensile face panel. 1/4" T-1 sweep blade liner and 3/16" T-1 slide blade liner available for even more longevity.

Rugged Hopper

3/16" T-1 lower hopper sides, 3/16" T-1 hopper floor standard. 3/16" T-1 hopper floor liner and 1/4" hopper sides and floor available. Abrasion is a huge problem, we've engineered the Legacy to not only be light but be strong using thick abrasion resistant steel to provide incomparable longevity.

Container Lifting Options

Multiple container lifting options available. Everything from carts to dumpsters and in whatever method you prefer 2-10 Reeving Winch, Hydraulic Drum Winch, Clear-Step Kickbar, etc.



Legacy-S

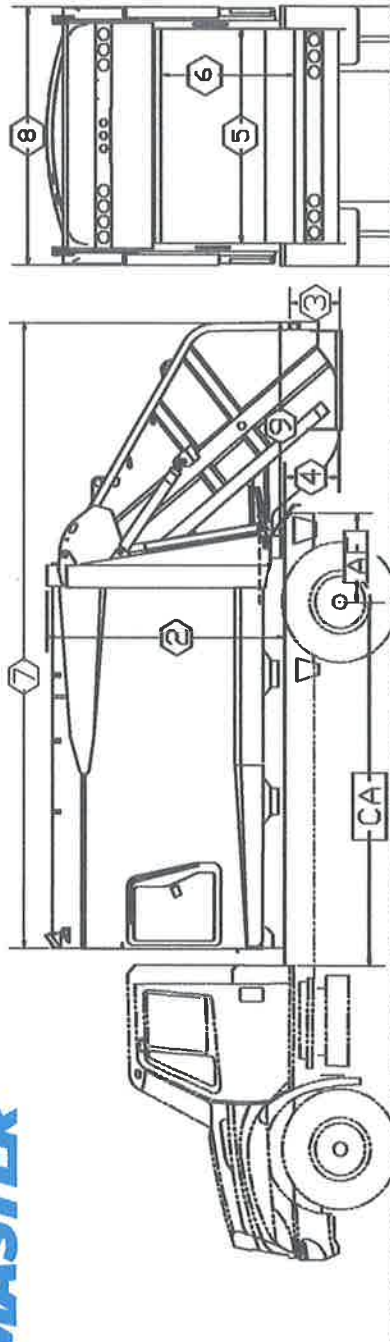

Dimensional Specifications

| | S 16 yd | S 18 yd | S 20 yd | S 25 yd |
|--|---------|---------|---------|---------|
| 1 Available Body Volumes | | | | |
| 2 Height Above Chassis Frame | 95 1/2" | 95 1/2" | 95 1/2" | 95 1/2" |
| 3 Depth of Hopper | 19" | 19" | 19" | 19" |
| 4 Hopper Below Chassis Frame | 25 1/2" | 25 1/2" | 25 1/2" | 25 1/2" |
| 5 Hopper Inside Width | 80" | 80" | 80" | 80" |
| 6 Hopper Opening Height | 60" | 60" | 60" | 60" |
| 7 Overall Length | 221" | 238" | 249" | 271" |
| 8 Overall Width | 96" | 96" | 96" | 96" |
| 9 Rear of Body to Rear of Tailgate | 81" | 81" | 81" | 81" |
| 10 Approximate Body Weight (lbs.) | 12,100 | 12,300 | 12,700 | 13,400 |
| 11 Load Sill Below Chassis Frame | 2 1/2" | 2 1/2" | 2 1/2" | 2 1/2" |
| 12 Hopper Capacity | 3 yd | 3 yd | 3 yd | 3 yd |
| 13 Height Above Frame (With Gate Raised) | 174 | 174 | 174 | 174 |

Standard Material Specifications

| | |
|-----------------------|--|
| Body Sides | 8 gauge grade 80 |
| Body Floor | 7 gauge |
| Body Roof | 8 gauge grade 80 |
| Floor Longitudinals | 3" x 10" x 3/16" boxed channel |
| Ejector Track channel | 1/4" elevated channel |
| Lower Tailgate Sides | 3/16" T-1 |
| Upper Tailgate Sides | 7 gauge in sweep zone 10 gauge above 3/16" T-1 |
| Hopper Floor | 3/16" AR 235 abrasion resistant |
| Separator Panel | 3/16" Grade 50 |
| Ejector Face Panel | UHMW main shoes Nylatron GSM yaw and pitch |
| Ejector Shoes | 3/16" T-1 alloy |
| Sweep Face Panel | 7 gauge Grade 80 |
| Slide Face Panel | Nylatron NSM |
| Slide Blade Shoes | |

Chassis Recommendations

| Body Size | Min. GVWR | Min. Front AWR | Min. Rear AWR | CT | Min. AF |
|-----------|-----------|----------------|---------------|------|---------|
| S 16 yd | 32,000 | 9,000 | 23,000 | 128" | 34" |
| S 18 yd | 32,000 | 9,000 | 23,000 | 140" | 34" |
| S 20 yd | 33,000 | 10,000 | 23,000 | 152" | 34" |
| S 25 yd | 39,000 | 12,000 | 27,000 | 170" | 34" |

Loadmaster's dedication to customer service and satisfaction means we will modify and customize options and features to meet the unique demands of any customer's route. To learn more about what Loadmaster can do for you, give your local dealership a call.

906.563.9226

LOADMASTER

LEGACY 3 SERIES

mid range rearloader

"SHORT" Lengths

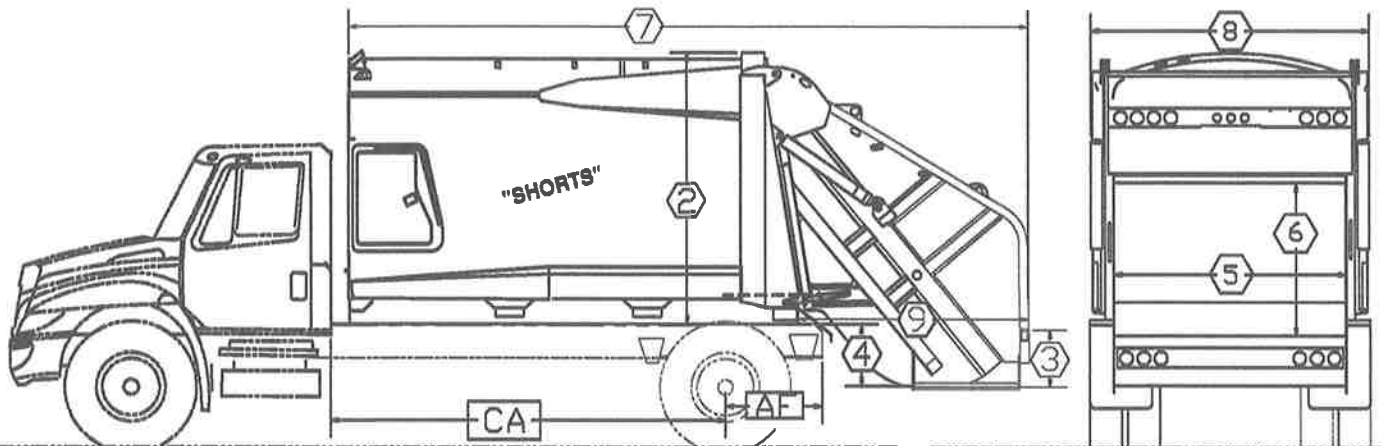

This Product Data Sheet is ONLY for "SHORT" length Legacy's (on Single Rear Axle chassis)

DIMENSIONAL SPECIFICATIONS for SHORT length LEGACY's

| 1 | AVAILABLE BODY VOLUMES → | Ⓢ16 YD ³ | Ⓢ18 YD ³ | Ⓢ20 YD ³ | Ⓢ25 YD ³ |
|----|---------------------------------------|---------------------|---------------------|---------------------|---------------------|
| 2 | HEIGHT ABOVE CHASSIS FRAME | 95 1/2 | 95 1/2 | 95 1/2 | 95 1/2 |
| 3 | DEPTH OF HOPPER | 19 | 19 | 19 | 19 |
| 4 | HOPPER BELOW CHASSIS FRAME | 25 1/2 | 25 1/2 | 25 1/2 | 25 1/2 |
| 5 | HOPPER INSIDE WIDTH | 80 | 80 | 80 | 80 |
| 6 | HOPPER OPENING HEIGHT | 60 | 60 | 60 | 60 |
| 7 | OVERALL LENGTH | 221 | 238 | 249 | 271 |
| 8 | OVERALL WIDTH | 96 | 96 | 96 | 96 |
| 9 | REAR OF BODY TO REAR OF TAILGATE | 81 | 81 | 81 | 81 |
| 10 | APPROX BODY WEIGHT | 12,100 LBS | 12,300 LBS | 12,700 LBS | 13,400 LBS |
| 11 | LOAD SILL BELOW CHASSIS FRAME | 2 1/2 INCH | 2 1/2 INCH | 2 1/2 INCH | 2 1/2 INCH |
| 12 | HOPPER CAPACITY | 3 YD ³ | 3 YD ³ | 3 YD ³ | 3 YD ³ |
| 13 | HEIGHT ABOVE FRAME (WITH GATE RAISED) | 174 | 174 | 174 | 174 |

Employ ONLY 22.5 Inch wheels & tires for any Legacy3 (do not spec 19.5 Inch)

Recommended Rear Tires for the "25S yard (only)" is 315R80-22.5 (If chassis is a S.R.A.)
If the Legacy 25S (or 20S) are to be "rare" TANDEM AXLE Chassis...see separate Product Data Sheet

LOADMASTER reserves the right to revise product specifications and without obligation.

THIS Product Data Sheet is ONLY for "SHORT" Length Legacy's

See "separate" Data Sheet for "standard" lengths. (and see "separate" Data Sheet for a tandem chassis)

This "DATA SHEET" is "Informational" only. Consult with your LOADMASTER dealer prior to ordering...for final specifications.

This DATA SHEET is solely for Single Rear Axles

For "CA"...assure Clear & Useable ... per this Info.
(If EXHAUST stack is "consuming" space... then "account" for EXHAUST when you are "spec'ing" the Chassis.)

LOADMASTER

loadmaster@loadmaster.org

800-433-2768

180 west eleventh avenue
po box 186
Norway, Michigan 49870-0186
fax 906-563-9800 fax

MAY 01, 2015

CHASSIS RECOMMENDATIONS for SHORT length LEGACY's

| BODY SIZE | MINIMUM GVWR | MINIMUM FRONT GAWR | MINIMUM REAR GAWR | CA | MINIMUM AF |
|---------------------|--------------|--------------------|-------------------|------|------------|
| Ⓢ16 YD ³ | 30,000 | 9,000 | 21,000 | 128" | 34" |
| Ⓢ18 YD ³ | 30,000 | 9,000 | 21,000 | 140" | 34" |
| Ⓢ20 YD ³ | 33,000 | 10,000 | 23,000 | 152" | 34" |
| Ⓢ25 YD ³ | 39,000 | 12,000 | 27,000 | 170" | 34" |

LEGACY 3 "BASE-PRODUCT" SPECIFICATIONS (16S, 18S, 20S, 25S VOLUMES ... "SHORT" Lengths)

Material Specifications-Body

| | |
|-------------------------|---|
| Body sides | 8 ga. high tensile (gr 80) |
| Body floor | 7 ga. high tensile |
| Body roof | 8 ga. high tensile (gr 80) |
| Floor longitudinals | 3" x 10" x 3/16" boxed channel |
| Ejector's track channel | 1/4" "hat" channel- elevated |
| | Many Body <i>structural</i> upgrades available (thicknesses and alloys) |

Material Specifications-Tailgate (3-yard hopper)

| | |
|----------------------|--|
| Lower tailgate sides | 3/16" T-1 (150ksi yield) |
| Upper tailgate sides | 7 ga. high tensile in "sweep" zone 10ga. high tensile above |
| Hopper floor | 3/16" T-1 alloy |
| Separator panel | 3/16" AR235 abrasion resistant |
| | Many Tailgate <i>structural</i> upgrades available (thicknesses, alloys) |



Material Specifications-Blades

| | |
|--------------------------|---|
| Ejector's face panel | HD rolled 3/16" Plate... 50KSI high tensile |
| Ejector's reinforces | 1/4" high tensile |
| Ejector's shoes | UHMW polyethylene main shoes w/ NYLATRON GSM yaw & pitch shoes |
| Sweep's face panel | 3/16" T-1 alloy (150ksi yield) |
| Sweep pusharms | 1/2" high tensile |
| Slide face blade | 7 ga. high tensile |
| Blade's wrist pin & axle | 2 1/2" med-carb; induction-hardened; with Hard Bushed sweep's wrist pivot |
| Slider's shoeing | durable NYLATRON NSM (a "engineering-grade" polymer) |

Hydraulic Specifications

| | | | |
|---------------------|--|-------------------------|---|
| Reservoir | 36 gallon | Sweep cylinders (2) | 4 1/2" bore |
| Pump | Direct-couple PTO- or- crank driven Front Pump | Slider cylinders (2) | 4 1/2" bore |
| Pump flow | 30-33 gallons per minute | Gate lift cylinders (2) | 3 1/2" single acting |
| Max system pressure | 3200 psi | Ejector telescopic (1) | 4-stage (6.5/5.5/4.5/3.5) |
| Suction filter | 100 mesh | Body-mounted valve | 2 function sectional |
| Return filter | 15 micron <i>microglass</i> tank-top | Tailgate-mtd. valve | 2 function sectional |
| | | | (Note: 3-stage telescopic used for 16S and 18S...6.5/ 5.5/ 4.5) |

Electrical Specifications

| | | | |
|------------------|-------------------------------|----------|---------------------------------|
| Wire | 14ga sxl | Switches | "grouped" rockers; in cab panel |
| Wire identifiers | color & function labeling | Lights | LED grommet-mounted style |
| Harnessing | multi-section; braid covering | | |
| Harness connects | Deutsch aircraft type | | |
| Wire connects | heat shrink sealed | | |

Some standard features

| | | |
|------------------------------------|-------------------------------------|-------------------------------------|
| Epoxy primer paint | Chromed cylinder rods | Regeneration (slider down function) |
| Undercoating | Cushioned slide and sweep cylinders | |
| Manual tailgate turnbuckle latches | Fully accessorized oil reservoir | |
| Body access door with ladder | Bolt-on riding steps | |
| Full complement of lights | Rear tailgate-mounted mudflaps | |
| Quick change shoeing | Color coded control levers | |

Some available options

| | |
|--------------------------------------|------------------------------------|
| Hot shift and air shift PTOs | Tool box |
| Work lights/ Strobe lights | "Customer-preferred" choices |
| "ClearStep" Roll Bar (3 yard) | Lower'd Load-Sill (1-1/2" lower'd) |
| Drum winch for containers | Body sump "Clean Out door(s)" |
| Roof-mtd. cable-reever ("2-10") | Automatic Tailgate Locks Option |
| Cart Tipper hydrau circuits & instal | Sling-Lift (2 yard) for containers |



100 West Eleventh Avenue
Post Office Box 186
Norway, MI 49870-0186

Phone: (906) 563-9226
FAX: (906) 563-9800
Toll Free: (800) 433-2768
Web Site: www.loadmaster.org

LOADMASTER NEW EQUIPMENT STANDARD 12 MONTH WARRANTY POLICY

Loadmaster Corporation, manufacturer of Loadmaster Refuse Equipment, herein referred to as Loadmaster, warrants for a period of twelve (12) months from the date placed in service by the first purchaser, each refuse collection body manufactured by Loadmaster to be free from defects in material and workmanship when operated for the purpose it was designed, and as described in the applicable operation manual. This warranty extends only to the first owner and shall not extend to any third party.

This warranty allocates the risk of product failure between Loadmaster and the Purchaser. This allocation is recognized by both parties and is reflected in the price. These remedies are the Purchaser's exclusive remedies for breach of this warranty. This warranty shall be subject to all of the provisions, terms and conditions of the Loadmaster Warranty Policy and Procedure Manual in which this warranty is embodied and shall be governed by, and construed in accordance with, the laws of the State of Michigan.

Loadmaster reserves the right, at any time to make changes in the design, material, function, and specifications of its equipment and/or accessories thereof without thereby becoming obligated to make similar changes in such products or accessories that were previously manufactured.

Unless modified in writing and signed by an officer of Loadmaster and the Purchaser, this warranty is understood to be the complete and exclusive agreement between the parties, superseding all prior agreements, oral or written, and all other communications between the parties relating to the subject matter of this warranty. No salesman, agent, employee or representative of Loadmaster or any other party is authorized to make any warranty in addition to those made herein. This warranty is not assignable by Purchaser.

LOADMASTER MAKES NO WARRANTY OF PRODUCTS MANUFACTURED BY OTHERS AND SUPPLIED BY LOADMASTER, THE SAME BEING SUBJECT TO WARRANTIES, IF ANY, OF THEIR RESPECTIVE MANUFACTURERS.

LOADMASTER SHALL NOT BE HELD LIABLE FOR SPECIAL, INCIDENTAL OR CONSEQUENTIAL DAMAGES OF ANY NATURE AS DEFINED IN THE LOADMASTER WARRANTY POLICY AND PROCEDURE MANUAL AND THE UNIFORM COMMERCIAL CODE, THE FOREGOING WARRANTIES ARE IN LIEU OF ALL OTHER WARRANTIES, WRITTEN, EXPRESSED OR IMPLIED, INCLUDING BUT NOT LIMITED TO THE IMPLIED WARRANTIES OF MERCHANTABILITY AND FITNESS FOR A PARTICULAR PURPOSE.

Before any warranty can be allowed on any new equipment the applicable warranty registration form must be on file with the Loadmaster Warranty Department.



100 West Eleventh Avenue
Post Office Box 186
Norway, MI 49870-0186

Phone: (906) 563-9226
FAX: (906) 563-9800
Toll Free: (800) 433-2768
Web Site: www.loadmaster.org

LOADMASTER STANDARD CYLINDER WARRANTY

LOADMASTER warrants all "rod-type" hydraulic cylinders of its manufacture against operational failure caused by defective material or workmanship, which occurs during normal use within 36 months from the date the product is first, put into service. First year is parts & labor. Years 2 & 3 are parts *only*.

Loadmaster's obligation is to repair or replace free of charge any part of any product that its inspection shows to be defective including the lowest roundtrip transportation charges from Loadmaster's customer to Norway, Michigan, and return, but excluding all transportation cost from dealer to its customer.

LOADMASTER shall not be liable for loss of time, manufacturing cost, labor, material, loss of profits, consequential damages, direct or indirect, because of defective products, whether due to rights arising under the contract of sale or independently thereof, and whether or not such claim is based on contract, tort or warranty.

Written permission for any warranty claim return must first be obtained from authorized LOADMASTER Personnel. All returns must be accompanied with a complete written explanation of claimed defects and the circumstances of operational failure.

PRODUCTS MANUFACTURED OR SOLD BY LOADMASTER ARE NOT WARRANTED EXPRESSLY OR BY IMPLICATION FOR MERCHANTABILITY OR FITNESS OR FOR ANY MEASURE OF SERVICE OR SUITABILITY OR FOR A SPECIFIC PURPOSE NOTWITHSTANDING ANY DISCLOSURE TO LOADMASTER OF THE USE TO WHICH THE PRODUCT IS TO BE PUT. THIS EXPRESS WARRANTY IS THE SOLE WARRANTY OF LOADMASTER. THERE ARE NO WARRANTIES WHICH EXTEND BEYOND THE WARRANTY HEREIN EXPRESSLY SET FORTH. THE SALE OF PRODUCTS OF LOADMASTER UNDER ANY OTHER WARRANTY OR GUARANTEE EXPRESS OR IMPLIED IS NOT AUTHORIZED.



SUBJECT: PX-9 Extended Warranty Update

**TSB # 20-27
DATE: 3-30-20**

The PX 9 engine offers one of the highest power-to-weight ratios in its class, with heavy-duty features like replaceable wet liners, roller cam followers, bypass oil filtration and targeted piston cooling. The PX-9 engine provides power to both medium and heavy-duty configurations, delivering durability and efficiency that result in uptime, performance and longevity.



Peterbilt is pleased to announce the introduction of **three new Aftertreatment PX-9 Protection Plan 1 extended warranty options with a duration of 6 years. Reference the table on page 4 for the new codes.**

| EPA 2017 PACCAR PX Engine Extended Protection Plans | | |
|---|--|--|
| | Protection Plan 1 | Protection Plan 2 |
| DURATION | Up to 5 years/ 250,000 mi (402,336 km) | Up to 7 years/ 250,000 mi (402,336 km) |
| Air compressor | • | |
| Fuel Injectors (excluding aftertreatment injector) | • | |
| Fuel pump | • | |
| Select engine sensors | • | |
| Turbocharger | • | |
| Water pump | • | |
| Cam follower assemblies | • | • |
| Camshaft and bushings | • | • |
| Connecting rod assembly | • | • |
| Crankshaft assembly | • | • |
| Cylinder block assembly | • | • |
| Cylinder head assembly | • | • |
| ECM | • | • |
| EGR cooler, valve, and mixer | • | • |
| Front gear cover | • | • |
| Lube oil cooler assembly | • | • |
| Lube pump assembly | • | • |
| Oil pan | • | • |
| Pistons, rings, and liners | • | • |
| Rocker lever assembly | • | • |



TRUCK SALES BULLETIN

***Note:** Remote diagnostic subscriptions are not included in the extended coverage package when purchased through Cummins.

| EPA 2017 PACCAR PX Engine Extended Protection Plan | |
|---|--|
| | Aftertreatment |
| DURATION | Up to 6 years/ 230,000 mi (402,396 km) |
| Ammonia sensor | • |
| Catalytic convertor particulate filter | • |
| Decomposition tube | • |
| Diesel exhaust fluid dosing unit | • |
| Diesel exhaust fluid dosing valve | • |
| Differential pressure sensor body | • |
| Differential pressure sensor body mounting hardware | • |
| Differential pressure sensor bracket | • |
| DPF temperature sensor (module & probe) | • |
| Fuel pressure sensor body | • |
| Fuel pressure sensor O-ring | • |
| Fuel return line | • |
| Fuel supply line | • |
| Injector (heavy duty only) | • |
| NOx & NH3 sensor module | • |
| NOx & NH3 sensor probe | • |
| SCR temperature sensor (module & probe) | • |
| SCR/DPF temperature sensor interface module mounting hardware | • |
| Selective catalytic reduction (SCR) catalyst | • |
| Temperature sensor connector | • |
| Wiring pigtail | • |

*Note: Plan covers failures under normal use and service, resulting from a defect in Cummins material or factory workmanship. Plans include registered parts and labor, with no deductible, on internally lubricated components and major engine systems.

There are three ways to add extended protection to a vehicle using the Vehicle Registration System:

1. Add the option code for the desired coverage to your order, prior to factory invoicing, and Peterbilt will register the engine coverage and customer information upon dealer completion of the Peterbilt online warranty registration.
2. Extended engine coverage may be added by the dealer at time of delivery to the customer under the Add/Remove Extended Warranties function while registering the vehicle.



TRUCK SALES BULLETIN

- Extended engine coverage may be added through Peterbilt by the dealer up to 12 months after the in service date under the Review Registration/Change Warranty function. For months, 13-18, please see a Cummins distributor.

*NOTE: This document is to be considered a summary of coverages and to be used for reference only and is not a binding document. For full warranty coverage details, see Cummins bulletins HD1- 5410615, HD2- 5410616, and 3381454 for full terms, conditions, and exclusions.

| | Description | Engine | Part # | Price | |
|--|---------------------------------|------------------------|---------------------------------|---------|---------|
| Protection Plan 1 | 4 years/ 150,000 mi/ 241,402 km | PX-7 | 9481739 | \$950 | |
| | 4 years/ 200,000 mi/ 321,869 km | <i>NOT YOUR ENGINE</i> | 9481740 | \$1,100 | |
| | 5 years/ 100,000 mi/ 160,935 km | | 9481741 | \$800 | |
| | 5 years/ 150,000 mi/ 241,402 km | | 9481742 | \$1,050 | |
| | 5 years/ 200,000 mi/ 321,869 km | | 9481743 | \$1,350 | |
| | 5 years/ 250,000 mi/ 402,336 km | | 9481744 | \$1,650 | |
| | 5 years/ 300,000 mi/ 482,804 km | | 9481745 | \$1,700 | |
| | 6 years/ 150,000 mi/ 241,402 km | | 9481746 | \$1,400 | |
| | 6 years/ 200,000 mi/ 321,869 km | | 9481747 | \$1,800 | |
| | 6 years/ 250,000 mi/ 402,336 km | | 9481748 | \$2,150 | |
| | Protection Plan 2 | | 4 years/ 150,000 mi/ 241,402 km | | 9481759 |
| 4 years/ 200,000 mi/ 321,869 km | | | | 9481760 | \$800 |
| 5 years/ 100,000 mi/ 160,935 km | | | 9481761 | \$650 | |
| 5 years/ 150,000 mi/ 241,402 km | | | 9481762 | \$800 | |
| 5 years/ 200,000 mi/ 321,869 km | | | 9481763 | \$900 | |
| 5 years/ 250,000 mi/ 402,336 km | | | 9481764 | \$1,000 | |
| 5 years/ 300,000 mi/ 482,804 km | | | 9481765 | \$1,050 | |
| 6 years/ 250,000 mi/ 402,336 km | | | 9481766 | \$1,100 | |
| 6 years/ 300,000 mi/ 482,804 km | | | 9481767 | \$1,250 | |
| 7 years/ 250,000 mi/ 402,336 km | | | 9481768 | \$1,300 | |
| Aftertreatment * Requires Protection Plan 1 | 4 years/ 150,000 mi/ 241,402 km | | 9481749 | \$575 | |
| | 4 years/ 200,000 mi/ 321,869 km | | 9481750 | \$650 | |
| | 5 years/ 100,000 mi/ 160,935 km | | 9481751 | \$575 | |
| | 5 years/ 150,000 mi/ 241,402 km | | 9481752 | \$650 | |
| | 5 years/ 200,000 mi/ 321,869 km | | 9481753 | \$750 | |
| | 5 years/ 250,000 mi/ 402,336 km | | 9481754 | \$850 | |
| | 5 years/ 300,000 mi/ 482,804 km | | 9481755 | \$900 | |
| | 6 years/ 150,000 mi/ 241,402 km | | 9481756 | \$737 | |
| | 6 years/ 200,000 mi/ 321,869 km | | 9481757 | \$904 | |
| | 6 years/ 250,000 mi/ 402,336 km | | 9481758 | \$987 | |



TRUCK SALES BULLETIN

| | Description | Engine | Part No. | Price | |
|---|--|---------------------------------|---------------------------------|---------|-------|
| Protection Plan 1 | 3 years/ 100,000 mi/ 160,935 km | PX-9 | 9481769 | \$900 | |
| | 3 years/ 150,000 mi/ 241,402 km | | 9481770 | \$1,150 | |
| | 4 years/ 150,000 mi/ 241,402 km | | 9481771 | \$1,800 | |
| | 4 years/ 200,000 mi/ 321,869 km | | 9481772 | \$2,600 | |
| | 5 years/ 100,000 mi/ 160,935 km | | 9481773 | \$1,750 | |
| | 5 years/ 150,000 mi/ 241,402 km | | 9481774 | \$2,190 | |
| | 5 years/ 200,000 mi/ 321,869 km | | 9481775 | \$3,000 | |
| | 5 years/ 250,000 mi/ 402,336 km | | 9481776 | \$4,000 | |
| | 5 years/ 300,000 mi/ 482,804 km | | 9481777 | \$5,000 | |
| | 6 years/ 150,000 mi/241,402 km | | 9481257 | \$2,750 | |
| | 6 years/ 200,000 mi/321,869 km | | 9481258 | \$3,550 | |
| | 6 years/ 250,000 mi/402,336 km | | 9481259 | \$4,550 | |
| | Protection Plan 2 | | 3 years/ 100,000 mi/ 160,935 km | 9481787 | \$750 |
| | | | 3 years/ 150,000 mi/ 241,402 km | 9481788 | \$825 |
| 4 years/ 150,000 mi/ 241,402 km | | 9481789 | \$1,300 | | |
| 4 years/ 200,000 mi/ 321,869 km | | 9481790 | \$1,550 | | |
| 5 years/ 100,000 mi/ 160,935 km | | 9481791 | \$1,200 | | |
| 5 years/ 150,000 mi/ 241,402 km | | 9481792 | \$1,400 | | |
| 5 years/ 200,000 mi/ 321,869 km | | 9481793 | \$1,650 | | |
| 5 years/ 250,000 mi/ 402,336 km | | 9481794 | \$1,900 | | |
| 5 years/ 300,000 mi/ 482,804 km | | 9481795 | \$2,150 | | |
| 6 years/ 250,000 mi/ 402,336 km | | 9481796 | \$2,000 | | |
| 7 years/ 250,000 mi/ 402,336 km | | 9481797 | \$2,250 | | |
| Aftertreatment * Requires Protection Plan 1 | | 3 years/ 100,000 mi/ 160,935 km | 9481778 | \$500 | |
| | | 3 years/ 150,000 mi/ 241,402 km | 9481779 | \$650 | |
| | | 4 years/ 150,000 mi/ 241,402 km | 9481780 | \$740 | |
| | 4 years/ 200,000 mi/ 321,869 km | 9481781 | \$900 | | |
| | 5 years/ 100,000 mi/ 160,935 km | 9481782 | \$740 | | |
| | 5 years/ 150,000 mi/ 241,402 km | 9481783 | \$910 | | |
| | 5 years/ 200,000 mi/ 321,869 km | 9481784 | \$1,070 | | |
| | 5 years/ 250,000 mi/ 402,336 km | 9481785 | \$1,250 | | |
| | 5 years/ 300,000 mi/ 482,804 km | 9481786 | \$1,500 | | |
| | 6 years/ 150,000 mi/ 241,402 km NEW | 9481542 | \$1,115 | | |
| 6 years/ 200,000 mi/ 321,869 km NEW | 9481543 | \$1,280 | | | |
| 6 years/ 250,000 mi/ 402,336 km NEW | 9481544 | \$1,502 | | | |

SmartSpec® Notes:

See SmartSpec for price, weight, and footnote information.

Contact your Regional Sales Office with any questions.



TRUCK SALES BULLETIN

SUBJECT: PETERBILT TRUCKCARE EXTENDED COVERAGE

**TSB # 18-110
DATE: 9-25-18**

Peterbilt offers several TruckCare® extended coverage packages to help customers protect their vehicle investment. Peterbilt is pleased to offer additional Basic Vehicle coverage options for Class 8 Models, noted in the table below.

The TruckCare packages cover the following systems:

- Basic Vehicle – Class 8 and Medium Duty Models
- Heater and Air Conditioning System – Class 8 and Medium Duty Models
- Peterbilt Rear Suspension – Class 8 Models
- Package for Heater / Air Conditioning System AND Peterbilt Rear Suspension – Class 8 Models

There are three ways to add extended coverage to a vehicle using the Vehicle Registration System:

1. Add the option code for the desired coverage to your order prior to factory invoicing and Peterbilt will register the coverage and customer information upon dealer completion of the Peterbilt online warranty registration.
2. Extended coverage can be added by the dealer at time of delivery to the customer under the Add/Remove Extended Warranties function while registering the vehicle.
3. Extended coverage may be added by the dealer up to 12 months after the in service date under the Review Registration / Change Warranty function in the Vehicle Registration system.

The available option codes and net prices in the table below apply to all orders submitted under the January 1, 2019, price level.

Orders in the Backlog:

Orders in the backlog accepted under a previous price level may be subjected to the Extended Coverage option codes in effect for that price level. Standard change order policy applies to dealer initiated changes on orders in the backlog.

AVAILABLE OPTIONS:

| Class 8 Models Extended Coverage | | | | | |
|----------------------------------|---------------------------------|----------------------|----------------|----------------------|------------------|
| Coverage Program | Duration | U.S. Option | U.S. Net Price | Canada Option | Canada Net Price |
| Basic Vehicle | 2 years/ 200,000 mi/ 320,000 km | 9401704 ¹ | \$1,265 | 9401724 ¹ | \$1,585 |
| | 2 years/ 300,000 mi/ 480,000 km | 9401705 ¹ | \$1,815 | 9401725 ¹ | \$2,270 |
| | 3 years/ 100,000 mi/ 160,000 km | 9402068 ¹ | \$1,650 | 9402074 ¹ | \$2,065 |
| | 3 years/ 300,000 mi/ 480,000 km | 9401706 ¹ | \$2,915 | 9401726 ¹ | \$3,645 |
| | 3 years/ 400,000 mi/ 640,000 km | 9401707 ¹ | \$3,475 | 9401727 ¹ | \$4,345 |
| | 3 years/ 500,000 mi/ 880,000 km | 9402293 ¹ | \$4,180 | 9402294 ¹ | \$5,225 |
| | 4 years/ 100,000 mi/ 160,000 km | 9402069 ¹ | \$2,475 | 9402075 ¹ | \$3,095 |



TRUCK SALES BULLETIN

| | | | | | |
|---|---|----------------------|---------|----------------------|---------|
| | 4 years/ 400,000 mi/ 640,000 km | 9402021 ¹ | \$4,370 | 9402027 ¹ | \$5,460 |
| | 4 years/ 500,000 mi/ 800,000 km | 9402022 ¹ | \$4,812 | 9402028 ¹ | \$6,015 |
| | 5 years/ 100,000 mi/ 160,000 km | 9402070 ¹ | \$2,915 | 9402076 ¹ | \$3,645 |
| | 5 years/ 150,000 mi/ 240,000 km | 9402071 ¹ | \$3,230 | 9402077 ¹ | \$4,040 |
| | 5 years/ 200,000 mi/ 320,000 km | 9402072 ¹ | \$3,550 | 9402078 ¹ | \$4,440 |
| | 5 years/ 250,000 mi/ 400,000 km | 9402073 ¹ | \$3,865 | 9402079 ¹ | \$4,830 |
| | 5 years/ 300,000 mi/ 480,000 km <i>NEW</i> | 9402384 ¹ | \$4,180 | 9402386 ¹ | \$5,225 |
| | 5 years/ 400,000 mi/ 640,000 km <i>NEW</i> | 9402385 ¹ | \$4,815 | 9402387 ¹ | \$6,015 |
| | 5 years/ 500,000 mi/ 800,000 km | 9402023 ¹ | \$5,445 | 9402029 ¹ | \$6,800 |
| Heater/Air Conditioner Systems | 2 years/ 200,000 mi/ 320,000 km | 9401692 ¹ | \$330 | 9401712 ¹ | \$415 |
| | 2 years/ 300,000 mi/ 480,000 km | 9401693 ¹ | \$495 | 9401713 ¹ | \$620 |
| | 3 years/ 300,000 mi/ 480,000 km | 9401694 ¹ | \$655 | 9401714 ¹ | \$820 |
| | 3 years/ 400,000 mi/ 640,000 km | 9401695 ¹ | \$765 | 9401715 ¹ | \$955 |
| | 4 years/ 400,000 mi/ 640,000 km | 9402024 ¹ | \$1,150 | 9402030 ¹ | \$1,440 |
| | 4 years/ 500,000 mi/ 800,000 km | 9402025 ¹ | \$1,340 | 9402031 ¹ | \$1,675 |
| | 5 years/ 500,000 mi/ 800,000 km | 9402026 ¹ | \$1,535 | 9402032 ¹ | \$1,920 |
| Peterbilt Rear Suspension | 2 years/ 200,000 mi/ 320,000 km | 9401696 ¹ | \$61 | 9401716 ¹ | \$77 |
| | 2 years/ 300,000 mi/ 480,000 km | 9401697 ¹ | \$88 | 9401717 ¹ | \$110 |
| | 3 years/ 300,000 mi/ 480,000 km | 9401698 ¹ | \$375 | 9401718 ¹ | \$390 |
| | 3 years/ 400,000 mi/ 640,000 km | 9401699 ¹ | \$400 | 9401719 ¹ | \$410 |
| Heater/Air Conditioner AND Peterbilt Rear Suspension | 2 years/ 200,000 mi/ 320,000 km | 9401700 ¹ | \$391 | 9401720 ¹ | \$490 |
| | 2 years/ 300,000 mi/ 480,000 km | 9401701 ¹ | \$583 | 9401721 ¹ | \$730 |
| | 3 years/ 300,000 mi/ 480,000 km | 9401702 ¹ | \$792 | 9401722 ¹ | \$990 |
| | 3 years/ 400,000 mi/ 640,000 km | 9401703 ¹ | \$963 | 9401723 ¹ | \$1205 |

| Medium Duty Models Extended Coverage | | | | | |
|---------------------------------------|---------------------------------|----------------------|----------------|----------------------|------------------|
| Coverage Program | Duration | U.S. Option | U.S. Net Price | Canada Option | Canada Net Price |
| Basic Vehicle | 2 years/ 150,000 mi/ 240,000 km | 9401710 ¹ | \$660 | 9401730 ¹ | \$825 |
| | 3 years/ 200,000 mi/ 320,000 km | 9401711 ¹ | \$1,320 | 9401731 ¹ | \$1,650 |
| | 4 years/ unlimited mi/km | 9402148 ¹ | \$2,145 | 9402150 ¹ | \$2,685 |
| | 5 years/ unlimited mi/km | 9402149 ¹ | \$2,970 | 9402151 ¹ | \$3,715 |
| Heater/Air Conditioner Systems | 2 years/ 150,000 mi/ 240,000 km | 9401708 ¹ | \$220 | 9401728 ¹ | \$275 |
| | 3 years/ 200,000 mi/ 320,000 km | 9401709 ¹ | \$363 | 9401729 ¹ | \$455 |

NOTES:

1. Price is NET and not subject to any discounts.

Orders in the Backlog

Standard change order policy applies to dealer initiated changes to orders in the backlog.



A PACCAR COMPANY

MEDIUM DUTY

Warranty Quick Reference Guide

This is a Quick Reference Guide "ONLY"

It is an itemized general listing of the components and/or items used in the assembly of a Peterbilt Vehicle and their respective level of warranty coverage. This list is NOT to be construed as all-inclusive. Refer to the complete text of the Peterbilt Warranty Agreement Cat. No. 4984, 7539, 7974 for specific details on the terms, conditions and limitations of said agreement.

BASIC VEHICLE WARRANTY

Air Cleaner System (Excludes Filter Element)

Air Conditioner System
 Accumulator
 Actuators, HVAC
 Blend, Mode, Fresh Air Doors
 Blower Motor & Wheel
 Coil, Heater
 Compressor, Freon
 Condenser
 Control, HVAC
 Drain Valve & Hose
 Expansion Valve
 Evaporator
 Freeze Control Switch
 Hardlines, Refrigerant
 Heater Hoses & Clamps
 Low/High Pressure Switches
 O-rings
 Receiver-Dryer
 Resistor
 Airshield
 Air System
 Air Compressor (Bendix)
 Air Dryer & Purge Valve
 Air Governor
 Air Tank & Drain Valve
 Alternator
 Antenna
 Auxiliary Heater Assembly (Espar)
 Auxiliary Transmissions
 Battery (PACCAR)
 Battery/Tool Box Assembly
 Battery Hold Downs
 Brake - Disc
 Chamber
 Camshaft
 Spider
 Drum (Excludes Scored or Heat Checked)
 Bumper (Includes Aerodynamic Type)
 Cab
 Heater and Duct
 Side Extender
 Skirt
 Water Leak
 Tilt Mechanism (Includes Pump)

Charge Air Cooler
 Charge Air Cooler Hoses & Clamps
 Circuit Breakers
 Clamps, Turbocharger Air Inlet
 Clock (Analog / Digital)
 Clutch, Clutch Linkage
 Collision Avoidance System
 Control Cable
 Cooling Module
 Cruise Control Component
 Deck Plate Lamp
 DEF Heater Control Relay
 DEF Heater Coolant Control Valve
 DEF Heated Lines
 DEF Heating Elements
 DEF Heating Fittings on Supply Module
 DEF Lamp
 DEF Tank
 Door Latch, Lock and Hinge
 Door Pad and Soft Trim
 Driveline, U-Joint and Center Bearing
 Driveline Midship Plate
 Electrical Power Distribution Box
 Electrical Printed Circuit & Harness (Excludes Fuse)
 Engine Related Components
 Engine Brake (PAC/Brake)
 Dipstick and Tube
 Fan, Fan Clutch and Sending Unit
 Fan Shroud
 Heater
 Manufactured Messaging Products
 Mount
 Shutdown System
 Exhaust Stanchion
 Exhaust piping, clamps, gaskets
 Fairing
 Fuel
 Fuel
 Tank
 Tank Strap, Cap and Vent
 Fuel Water Separator and/or Heater
 Gauge and Sending Unit
 Heat Shield
 Hood Assist Spring and Hook
 Horn - Air or Electric
 Hose and Fitting (Excludes Rubbed or Loose)
 Hub Assembly (Excludes Bearing and Races)
 Hub Caps

12 Months / Unlimited Miles / Kilometers whichever comes first

Hubometer
 Ignition Timer
 Instruments
 Lift/Tag/Pusher Axle
 Lift/Tag/Pusher Suspension
 Light Fixture (Excludes Bulb)
 Mirror
 Mud Flap Bracket (Excludes Mud Flap)
 Muffler
 Muffler Clamps
 Muffler Standpipe
 Navigation System (Smart Nav)
 Plating (Includes Chrome)
 Power Steering Pump
 Power Steering Reservoir
 Quarter Fender
 Radiator (Includes Header Gasket)
 Radiator Cap
 Radiator Mounting Brackets
 Radiator Mounting Bushings
 Radiator, Tie Rods
 Radio/CB (Unlimited Mileage)
 Relay
 Seat Assembly
 Seat Belt
 Seat Structure
 Shift Control
 Shock Absorber
 Slack Adjuster
 Sleeper Boot
 Sleeper Extender
 Speaker
 Starter
 Steering
 Shaft and U-Joint
 Drag Link
 Gear Mounting Bracket
 Pitman Arm
 Steering Wheel and Column
 Step
 Supplemental Restraint System (Rollover Airbag)
 Suspension
 Axle
 Beams
 Dowel Pin
 Height Control Valve

Suspension - Continued
 Height Control Valve Bracket
 Height Control Valve Linkage
 Shock Bracket & Stud
 Spring, Air
 Spring Bracket
 Spring, Leaf
 Spring Pin
 Spring Saddles
 Spring Shackie & Pins
 Torque Rods
 Tracking Rods & Brackets
 U-Bolts & U-Bolt Saddles
 Cab
 Height Control Valve
 Height Control Valve Bracket
 Height Control Valve Linkage
 Spring, Air
 Sleeper
 Height Control Valve
 Height Control Valve Bracket
 Height Control Valve Linkage
 Spring, Air
 Suspension Bushings
 Throttle Linkage and Cable
 Transfer Case
 Transmission Shift Control & Oil Cooler
 Turbocharger Piping, Clamps & Gaskets to Inlet of SCR
 Upholstery (Excludes Wear)
 Valve, All
 Vent - Fresh Air
 Visor (Outside and Inside)
 Weather Stripping
 Wheel Bearing (Wear Not Covered)
 Window Defroster Fan
 Window Lift (Includes Power Lift)
 Window Regulator
 Windshield Washer
 Wiper Arm (Excludes Wiper Blade)
 Wiper Motor and Control Valve
 Wiring and Connectors (Excludes Visible Rubbed or Loose)

PAINT

- Cab, Hood, Sleeper Paint
 - Frame Paint - Black Only
 - Frame Paint - All colors other than black
 - Frame Paint - Logger, Mixer, Dump, Refuse, Oil Field & Construction application

12 Months 100,000 Miles / 160,000 Kilometers
 12 Months 100,000 Miles / 160,000 Kilometers
 6 Months 50,000 Miles / 80,000 Kilometers
 3 Months 25,000 Miles / 40,000 Kilometers

MAJOR COMPONENTS
24 Months or Unlimited Miles / Kilometers whichever shall occur first. 100% Parts and Labor

Axle - Eaton, Meritor and Dana Spicer Axles, Non-Driving and Driving, Single Speed, On-Highway with a Capacity of 46,000 Lbs. or Less (Includes Axle Input and Output Seals)(Excludes Axle Shaft Flange Gaskets, Brake Drums, Brake Shoes, Filters, Hub Assemblies, Hub Caps and Gaskets, Wheel Bearings and Wheel Seals)
Brakes - Bendix and Meritor (except Air disc Brakes)
Applies to Brackets, Cam Shafts, Slack Adjusters and Spindles
Cab, Hood, Hood Half-Fenders and Sleeper Structure
Cab Fasteners (Excludes Add-On Aerodynamic Devices)
Sheppard and TRW Steering Gears
Manual Transmissions (Excludes Oil Coolers and Shift Controls)
Eaton Auto Shift Transmission

FRAME RAILS, GUSSETS, CROSSMEMBERS AND CAB / HOOD / or SLEEPER CORROSION
36 Months or Unlimited Miles / Kilometers whichever shall occur first. 100% Parts and labor
Frame Side Rails, Crossmembers, Gussets, A-Braces

Cab, Hood and Sleeper perforation caused by corrosion from within. Corrosion warranty applies to perforation - an actual hole in a cab, hood or sleeper panel due to corrosion. Warranty does not apply to corrosion caused by damage to a cab panel or finish paint.

OTHER COVERAGES
12 Months or 50,000 Miles/80,000 Kilometers whichever shall occur first. 100% Parts and Labor

Axle Shaft Flange Gaskets Wheel Seals (Except LMS)
Hub Cap Gaskets All Gaskets and Seals not specified above

General Warranty Exclusions

- The following components are warranted directly to you by their respective manufacturer, and are not warranted by Peterbilt Motors Company: Engine and Engine Manufacturer's Accessories, Engine Brake (except PAC Brake), Automatic Transmissions, Tires, Tubes, Fifth Wheel, Pintle Hooks, Hitch, Wheels and Batteries not listed.
- Peterbilt does not warrant antifreeze, lubricants, bulbs, fuses, filters, mud flaps, reflectors, winter fronts, wiper nozzles or wiper blades. Trade accessories such as fire extinguishers, chains, emergency kits and tools are not warranted.
- Peterbilt is not responsible for storage deterioration, wear, and changes in adjustment resulting from normal service. This includes brake and clutch linings, drive belts, wheel balance and axle alignments or upholstery.
- Peterbilt does not warrant metallic chassis (frame) paint. Peterbilt is not responsible for paint chipping or fading, peeling from frame bolts relating to maintenance, or paint peeling from road chemical damage.
- Damage due to accident, misuse, negligence, improper or inadequate maintenance, or unauthorized modification is not warranted. Failure of replacement parts used to repair above conditions are not warrantable.
- Vibrations, squeaks, fitting and hose leaks, unusual noises, rattles, loose nuts/bolts and hose and electrical connections can develop during the early shakedown trips of the vehicle. Up to 25,000 miles/40,000 kilometers, but not later than 90 days after date of delivery, the necessary adjustments will be made without charge. Such developments after this period are usually the result of use and are not warrantable items.
- Peterbilt is not responsible for damage resulting from engine horsepower/torque upgrades.

NON - WARRANTABLE COMPONENTS/ITEMS

File with Engine Manufacturer
Engine (see engine coverage)
Engine Accessories
Air Compressor (Engine Manufacturer)
Add-On Aerodynamic Device (Dealer Installed)
Antifreeze Solution
Automatic Transmission (Allison)
Brake Lining
Bulb
Fifth Wheel
Filter Element
Fire Extinguisher
Flag and Flare Kit
Fuel
Fuse

NON - WARRANTABLE:

WEAR, DETERIORATION and/or ADJUSTMENTS

Peterbilt assumes no responsibility for wear and/or Deterioration of parts or Changes in Adjustment as a result of Normal Service.

Examples:

Brake Adjustment
Brake Drum
Brake Lining
Bushings (Serviceable)
Clutch Facing
Engine Accessory Belt
Fuse
Key Fob
Wheel Bearings

Mattress
Paint Chip and/or Fade
Soft Trim and Upholstery
Stainless Steel Discoloration
Tightening a Bolt and/or Fitting
Wheel and/or Axle Alignment
Window and Windshield Glass

This list is NOT to be construed as all-inclusive

NON - WARRANTABLE FUNCTIONS OR ACTS

Any Vehicle on Which the Odometer has been Altered
Any Vehicle that has been Altered or Modified in a Manner Unauthorized by Peterbilt

Damage Due to Accidents
Dyno Testing (Without Prior Regional Authorization)
Improper or Insufficient Maintenance Service
Misuse
Negligence
Storage (Includes Deterioration)
Towing and Road Calls
Transport
Troubleshooting and Road Testing

2020 Allison Transmission Coverage Pricing Guide

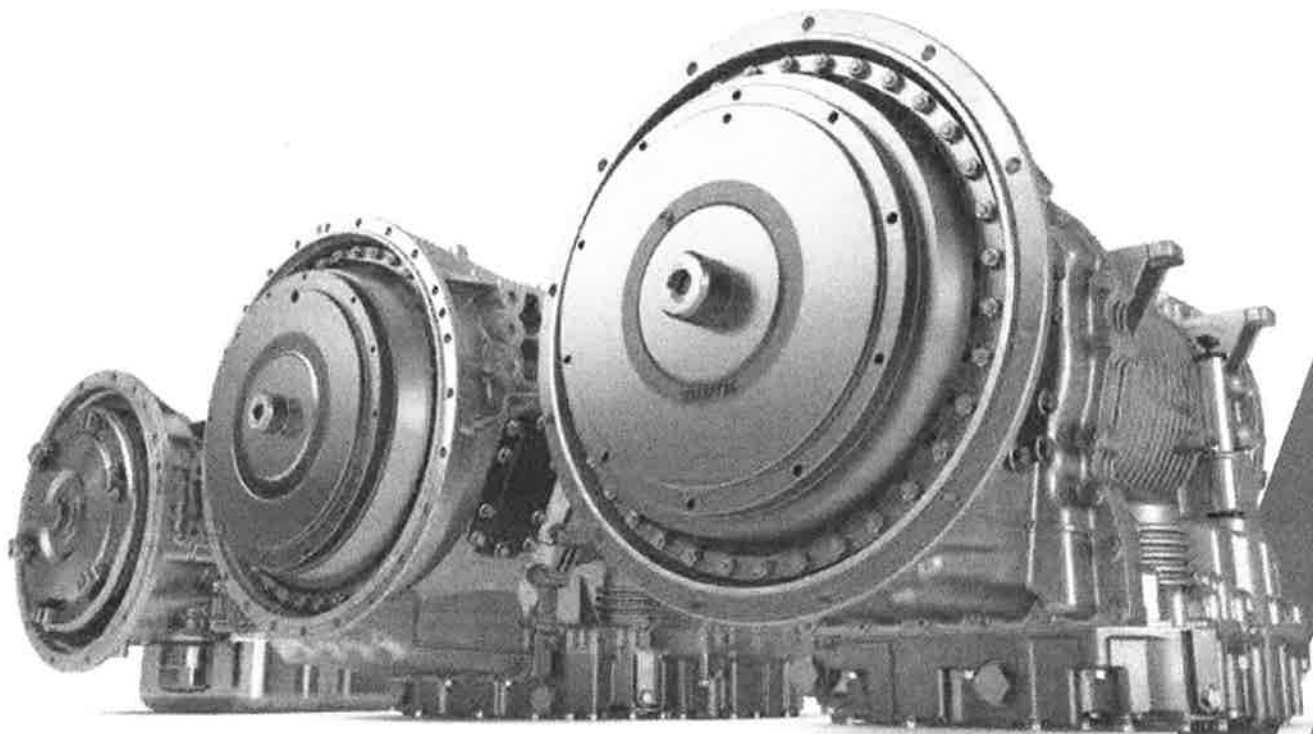

Improving The Way The World Works



Terms and Conditions for

Allison Transmission Coverage

Transmission Coverage Definitions and Requirements

Standard Limited Warranty

All Allison automatic transmissions carry a Standard Limited Warranty based upon Vocational Model Series and vocations*. Standard Limited Warranty includes 100% parts and labor for the designated coverage period. Mileage limitations for specific Vocational Model Series and/or vocations may apply.

Coverage Pricing

Extended Transmission Coverage must be purchased within one year of the delivery of the vehicle. Pricing shown in this brochure is applicable to Extended Transmission Coverage purchased in 2020.

Suggested retail prices are established for each transmission vocational model/vocation combination.

The terms and conditions under which Allison Transmission offers Extended Transmission Coverage are set forth on the back of the Extended Transmission Coverage Agreement Registration, available from any Allison Authorized Distributor or Dealer.

Pricing and/or coverage details shown in the following charts are subject to change without notice. All pricing is in US Dollars. For current prices and coverage information, go to allisontransmission.com.

Extended Transmission Coverage

In addition to Standard Limited Warranty and Partnership coverage, Allison transmissions listed in this brochure are eligible for Extended Transmission Coverage. Extended Transmission Coverage begins at the end of the Standard Limited Warranty and Partnership coverage period and increases the coverage period. Extended Transmission Coverage is available for purchase through Allison Authorized Distributors and Dealers. Details for Extended Transmission Coverage are shown on the following charts.

REQUIREMENTS: Use of Allison Approved TES 295® transmission fluid** and Genuine Allison Filters is required. Failure to use Allison Approved TES 295 transmission fluid and Genuine Allison Filters will result in no coverage for repair beyond Standard Limited Warranty coverage. Transmissions that are

not OEM factory filled with Allison Approved TES 295 transmission fluid and Genuine Allison Filters must have Allison Approved TES 295 transmission fluid and Genuine Allison Filters installed at the time of Extended Transmission Coverage purchase. Transmissions that are not OEM factory filled with Allison Approved TES 295 transmission fluid, or transmissions operating with non-TES 295 fluids, must be drained and filled with Allison Approved TES 295 transmission fluid to achieve 100% concentration. One hundred percent concentration is not achieved until the second consecutive fluid change using Allison Approved TES 295 transmission fluid. The second consecutive fluid change must be achieved at the time of Extended Transmission Coverage purchase.

NOTE: Except as noted, all transmissions with Extended Transmission Coverage have 100% parts and labor coverage with no mileage limitations.

Partnership Coverage

Some Allison-equipped vehicles purchased through Allison Partnerships carry Partnership Coverage. Partnership Coverage begins at the end of the Standard Limited Warranty period. Duration of Partnership Coverage varies depending upon the Vocational Model Series purchased.

REQUIREMENTS: Use of Allison Approved TES 295 transmission fluid and Genuine Allison Filters is required. Failure to use Allison Approved TES 295 transmission fluid and Genuine Allison Filters will result in no coverage for repairs beyond Standard Limited Warranty.

NOTE: Except as noted, all transmissions with Partnership Coverage beyond Standard Limited Warranty have 100% parts and labor coverage with no mileage limitations.

NOTE: Partnership Coverage only applies to units shipped before January 1, 2020.

* See Warranty Parchment for exact coverage details.

** For a list of current Allison Approved TES 295 transmission fluids, go to: allisontransmission.com; click on Parts + Service, then Approved Fluids.

2020 Allison Transmission Coverage Pricing Guide

| RUGGED DUTY SERIES™ | | Standard Limited Warranty | Extended Transmission Coverage* | |
|---------------------|--------------------|---------------------------|---------------------------------|---------|
| Model | Vocation | Years of Coverage | 2 Years | 4 Years |
| 1000 RDS | P&D and Beverage | 3 | \$361 | N/A |
| | Utility and Other | 3 | \$361 | N/A |
| | Dump Trucks/Mixers | 3 | \$281 | N/A |
| | Agriculture | 3 | \$281 | N/A |
| 1000 RDS xFE | P&D and Beverage | 3 | \$361 | N/A |
| | Utility and Other | 3 | \$361 | N/A |
| | Dump Trucks/Mixers | 3 | \$281 | N/A |
| | Agriculture | 3 | \$281 | N/A |
| 1350 RDS | P&D and Beverage | 3 | \$319 | N/A |
| | Utility and Other | 3 | \$487 | N/A |
| | Dump Trucks/Mixers | 3 | \$487 | N/A |
| | Agriculture | 3 | \$487 | N/A |
| 1350 RDS xFE | P&D and Beverage | 3 | \$319 | N/A |
| | Utility and Other | 3 | \$487 | N/A |
| | Dump Trucks/Mixers | 3 | \$487 | N/A |
| | Agriculture | 3 | \$487 | N/A |
| 2100 RDS | P&D and Beverage | 3 | \$552 | \$773 |
| | Utility and Other | 3 | \$552 | \$773 |
| | Dump Trucks/Mixers | 3 | \$547 | \$765 |
| | Agriculture | 3 | \$547 | \$765 |
| 2100 RDS xFE | P&D and Beverage | 3 | \$552 | \$773 |
| | Utility and Other | 3 | \$552 | \$773 |
| | Dump Trucks/Mixers | 3 | \$547 | \$765 |
| | Agriculture | 3 | \$547 | \$765 |
| 2200RDS | P&D and Beverage | 3 | \$541 | \$758 |
| | Utility and Other | 3 | \$541 | \$758 |
| | Dump Trucks/Mixers | 3 | \$541 | \$758 |
| | Agriculture | 3 | \$541 | \$758 |
| 2200 RDS xFE | P&D and Beverage | 3 | \$541 | \$758 |
| | Utility and Other | 3 | \$541 | \$758 |
| | Dump Trucks/Mixers | 3 | \$541 | \$758 |
| | Agriculture | 3 | \$541 | \$758 |
| 2300 RDS | P&D and Beverage | 3 | \$555 | \$777 |
| | Utility and Other | 3 | \$555 | \$777 |
| | Dump Trucks/Mixers | 3 | \$555 | \$777 |
| | Agriculture | 3 | \$555 | \$777 |
| 2350 RDS | P&D and Beverage | 3 | \$549 | \$769 |
| | Utility and Other | 3 | \$549 | \$769 |
| | Dump Trucks/Mixers | 3 | \$549 | \$769 |
| | Agriculture | 3 | \$549 | \$769 |
| 2350 RDS xFE | P&D and Beverage | 3 | \$549 | \$769 |
| | Utility and Other | 3 | \$549 | \$769 |
| | Dump Trucks/Mixers | 3 | \$549 | \$769 |
| | Agriculture | 3 | \$549 | \$769 |
| 2500 RDS | P&D and Beverage | 3 | \$478 | \$669 |
| | Utility and Other | 3 | \$478 | \$669 |
| | Dump Trucks/Mixers | 3 | \$478 | \$669 |
| | Agriculture | 3 | \$478 | \$669 |
| 2500 RDS xFE | P&D and Beverage | 3 | \$478 | \$669 |
| | Utility and Other | 3 | \$478 | \$669 |
| | Dump Trucks/Mixers | 3 | \$478 | \$669 |
| | Agriculture | 3 | \$478 | \$669 |
| 2550 RDS | Refuse Packer | 3 | \$1,066 | \$1,492 |
| | Utility and Other | 3 | \$549 | \$769 |
| | Dump Trucks/Mixers | 3 | \$549 | \$769 |
| | Agriculture | 3 | \$549 | \$769 |
| 2550 RDS xFE | P&D and Beverage | 3 | \$549 | \$769 |
| | Refuse Packer | 3 | \$1,066 | \$1,492 |
| | Utility and Other | 3 | \$549 | \$769 |
| | Dump Trucks/Mixers | 3 | \$549 | \$769 |
| 2550 RDS | P&D and Beverage | 3 | \$549 | \$769 |
| | Utility and Other | 3 | \$549 | \$769 |
| | Dump Trucks/Mixers | 3 | \$549 | \$769 |
| | Agriculture | 3 | \$549 | \$769 |

| RUGGED DUTY SERIES™ | | Standard Limited Warranty | Extended Transmission Coverage* | |
|---------------------|--------------------|---------------------------|---------------------------------|---------|
| Model | Vocation | Years of Coverage | 2 Years | 4 Years |
| 3000 RDS | P&D and Beverage | 3 | \$482 | N/A |
| | Refuse Packer | 3 | \$938 | N/A |
| | Utility and Other | 3 | \$482 | N/A |
| | Dump Trucks/Mixers | 3 | \$482 | \$1,020 |
| 3000 RDS R** | Agriculture | 3 | \$482 | N/A |
| | P&D and Beverage | 3 | \$704 | N/A |
| | Refuse Packer | 3 | \$1,143 | N/A |
| | Utility and Other | 3 | \$704 | N/A |
| 3500 RDS | Dump Trucks/Mixers | 3 | \$704 | \$2,025 |
| | Agriculture | 3 | \$704 | N/A |
| | P&D and Beverage | 3 | \$487 | N/A |
| | Refuse Packer | 3 | \$947 | N/A |
| 3500 RDS R** | Utility and Other | 3 | \$487 | N/A |
| | Dump Trucks/Mixers | 3 | \$487 | \$1,175 |
| | Agriculture | 3 | \$487 | N/A |
| | P&D and Beverage | 3 | \$607 | N/A |
| 4000 RDS | Refuse Packer | 3 | \$1,060 | N/A |
| | Utility and Other | 3 | \$607 | N/A |
| | Dump Trucks/Mixers | 3 | \$607 | \$2,153 |
| | Agriculture | 3 | \$607 | N/A |
| 4000 RDS R** | P&D and Beverage | 3 | \$877 | N/A |
| | Refuse Packer | 3 | \$1,154 | N/A |
| | Utility and Other | 3 | \$877 | N/A |
| | Dump Trucks/Mixers | 3 | \$877 | \$1,609 |
| 4500 RDS | Agriculture | 3 | \$877 | N/A |
| | P&D and Beverage | 3 | \$1,166 | N/A |
| | Refuse Packer | 3 | \$1,429 | N/A |
| | Utility and Other | 3 | \$1,166 | N/A |
| 4500 RDS R** | Dump Trucks/Mixers | 3 | \$1,166 | \$2,286 |
| | Agriculture | 3 | \$1,166 | N/A |
| | P&D and Beverage | 3 | \$826 | N/A |
| | Refuse Packer | 3 | \$1,052 | N/A |
| 4700 RDS | Utility and Other | 3 | \$826 | N/A |
| | Dump Trucks/Mixers | 3 | \$826 | \$1,472 |
| | Agriculture | 3 | \$826 | N/A |
| | P&D and Beverage | 3 | \$910 | N/A |
| 4700 RDS R** | Refuse Packer | 3 | \$1,152 | N/A |
| | Utility and Other | 3 | \$910 | N/A |
| | Dump Trucks/Mixers | 3 | \$910 | \$1,784 |
| | Agriculture | 3 | \$910 | N/A |
| 4700 RDS | P&D and Beverage | 3 | N/A | N/A |
| | Refuse Packer | 3 | \$1,532 | N/A |
| | Utility and Other | 3 | \$1,596 | N/A |
| | Dump Trucks/Mixers | 3 | \$1,224 | \$2,876 |
| 4700 RDS R** | Agriculture | 3 | \$1,272 | N/A |
| | P&D and Beverage | 3 | N/A | N/A |
| | Refuse Packer | 3 | \$2,171 | N/A |
| | Utility and Other | 3 | \$1,846 | N/A |
| 4700 RDS R** | Dump Trucks/Mixers | 3 | \$1,846 | \$4,375 |
| | Agriculture | 3 | \$1,846 | N/A |

Rugged Duty applications with a 2200/2500/3000 RDS Series™ may have additional coverage. Contact your distributor for additional information.

* Extended Transmission Coverage: Available for purchase through Allison Authorized Distributors and Dealers to increase coverage

** Retarder Option



City Council Agenda Form

Meeting Date: September 15, 2020
Agenda Item Title: Advanced Metering Infrastructure
Department: Electric

Agenda Item Description: Tantalus Meters

Background: The Electric Department has been contacted by the City of Hugoton, KS and presented with an opportunity to purchase a quantity of Itron Tantalus Electric Meters at a reduced cost savings of 25% on new in the box meters, and 50% savings on meters that have been in service for around one year. If we were to purchase only the new meters, it would result in a savings of \$27,374.00. If we were to purchase all meters, it would result in a savings of \$54,014.50.

City Attorney Review/ Comment: NA

Funding Source: Electric Depreciation

Options:

1. Authorize the Purchase of New meters from the City of Hugoton for \$92,737.00
2. Authorize the Purchase of all meters from the City of Hugoton for \$163,117.00
3. Alternative Purchase Quantities
4. Decline the Purchase of Meters from the City of Hugoton

Staff Recommendation: Approve and authorize the Electric Department to purchase New meters from the City of Hugoton in the amount of \$92,737.

Attachment(s): Price Sheet

| 2S | Residential Meters | \$ PER MTR | TOTAL | Full Cost Comparison | SAVINGS |
|-----------------------------------|--------------------|------------|--------------|------------------------|--------------|
| NEW | 755 | \$ 75.00 | \$ 56,625.00 | \$ 99.30 \$ 74,971.50 | \$ 18,346.50 |
| USED | 400 | \$ 50.00 | \$ 20,000.00 | \$ 99.30 \$ 39,720.00 | \$ 19,720.00 |
| ASSORTED POLY PHASE METERS | | | | | |
| NEW | 122 | \$ 296.00 | \$ 36,112.00 | \$ 370.00 \$ 45,140.00 | \$ 9,028.00 |
| USED | 40 | \$ 197.00 | \$ 7,880.00 | \$ 370.00 \$ 14,800.00 | \$ 6,920.00 |

Russell Police



Department

Est. 1872

ACTIVITY REPORT FOR 2020

INCIDENTS REPORTED

| OFFENSES | Jan | Feb | Mar | April | May | June | July | Aug | Sept | Oct | Nov | Dec | Total |
|--------------------|-----|-----|-----|-------|-----|------|------|-----|------|-----|-----|-----|-------|
| Offenses Reports | 29 | 28 | 26 | 21 | 32 | 32 | 33 | 26 | | | | | 227 |
| Supplement Reports | 7 | 3 | 11 | 4 | 12 | 8 | 8 | 47 | | | | | 100 |
| Non-Crime Reports | 8 | 12 | 8 | 7 | 11 | 15 | 8 | 13 | | | | | 82 |
| Felony | 6 | 5 | 11 | 2 | 6 | 6 | 9 | 13 | | | | | 58 |
| Misdemeanor | 23 | 23 | 15 | 19 | 26 | 26 | 24 | 13 | | | | | 169 |

CRIMINAL ENFORCEMENT ACTIVITIES

| DESCRIPTION | Jan | Feb | Mar | April | May | June | July | Aug | Sept | Oct | Nov | Dec | Total |
|-----------------------|-----|-----|-----|-------|-----|------|------|-----|------|-----|-----|-----|-------|
| Adult Arrest | 17 | 20 | 1 | 7 | 7 | 8 | 10 | 18 | | | | | 88 |
| Juvenile Arrest | 6 | 1 | 5 | 0 | 1 | 1 | 2 | 2 | | | | | 18 |
| Child in Need of Care | 1 | 3 | 0 | 0 | 2 | 1 | 3 | 1 | | | | | 11 |
| Total Custody | 23 | 23 | 6 | 7 | 10 | 9 | 12 | 21 | | | | | 111 |
| Alcohol Related | 1 | 0 | 4 | 1 | 1 | 1 | 0 | 1 | | | | | 9 |
| Drug Related | 3 | 4 | 0 | 2 | 0 | 1 | 1 | 5 | | | | | 16 |
| Curfew Violation | 0 | 0 | 0 | 1 | 0 | 0 | 0 | 0 | | | | | 1 |

INVESTIGATION ACTIVITIES

| DESCRIPTION | Jan | Feb | Mar | April | May | June | July | Aug | Sept | Oct | Nov | Dec | Total |
|---------------------------|-----|-----|-----|-------|-----|------|------|-----|------|-----|-----|-----|-------|
| Total Cases Assigned | 34 | 35 | 42 | 21 | 37 | 43 | 49 | 41 | | | | | 302 |
| Total Active Cases | 4 | 5 | 17 | 9 | 11 | 15 | 17 | 12 | | | | | 90 |
| Cases Referred | 9 | 10 | 2 | 8 | 7 | 8 | 13 | 6 | | | | | 63 |
| Adult Affidavits Filed | 5 | 10 | 0 | 1 | 2 | 0 | 7 | 2 | | | | | 27 |
| Juvenile Affidavits Filed | 6 | 1 | 1 | 1 | 0 | 0 | 3 | 1 | | | | | 13 |
| Follow-Up Contacts | 6 | 2 | 9 | 16 | 1 | 3 | 3 | 0 | | | | | 40 |
| Search Warrants | 1 | 0 | 0 | 0 | 2 | 1 | 1 | 0 | | | | | 5 |

TRAFFIC ACCIDENT INVESTIGATIONS

| DESCRIPTIONS | Jan | Feb | Mar | April | May | June | July | Aug | Sept | Oct | Nov | Dec | Total |
|----------------------|-----|-----|-----|-------|-----|------|------|-----|------|-----|-----|-----|-------|
| Injury Accidents | 0 | 0 | 1 | 1 | 0 | 0 | 3 | 3 | | | | | 8 |
| Non-Injury Accidents | 1 | 4 | 3 | 4 | 3 | 7 | 6 | 10 | | | | | 38 |
| TOTAL ACCIDENTS | 2 | 7 | 7 | 7 | 6 | 8 | 14 | 16 | | | | | 67 |
| Private Property | 1 | 3 | 3 | 2 | 3 | 1 | 5 | 3 | | | | | 21 |

PATROL ACTIVITIES

| DESCRIPTION | Jan | Feb | Mar | April | May | June | July | Aug | Sept | Oct | Nov | Dec | Total |
|------------------------|-----|-----|-----|-------|-----|------|------|-----|------|-----|-----|-----|-------|
| Community Policing | 0 | 1 | 0 | 1 | 0 | 2 | 1 | 0 | | | | | 5 |
| Speeding Citation | 1 | 1 | 2 | 1 | 2 | 0 | 1 | 1 | | | | | 2 |
| Other Traffic Citation | 12 | 6 | 10 | 11 | 15 | 3 | 9 | 8 | | | | | 74 |
| Parking Warning | 6 | 4 | 4 | 4 | 2 | 0 | 2 | 1 | | | | | 23 |
| DUI Arrest | 1 | 0 | 0 | 2 | 0 | 0 | 0 | 1 | | | | | 4 |
| Vacation Watches | 0 | 4 | 0 | 0 | 0 | 0 | 0 | 3 | | | | | 7 |
| Open Buildings | 3 | 0 | 0 | 2 | 3 | 1 | 0 | 2 | | | | | 583 |
| Public Assists | 61 | 56 | 42 | 58 | 81 | 91 | 94 | 100 | | | | | 66 |
| Alarms | 11 | 4 | 9 | 9 | 6 | 9 | 6 | 12 | | | | | 66 |
| Animal Complaints | 12 | 37 | 19 | 31 | 28 | 25 | 47 | 47 | | | | | 246 |
| Subpoena Served | 5 | 6 | 0 | 0 | 0 | 14 | 12 | 7 | | | | | 44 |

TRAINING HOURS RECEIVED

| DESCRIPTION | Jan | Feb | Mar | April | May | June | July | Aug | Sept | Oct | Nov | Dec | Total |
|----------------------|-----|-----|-----|-------|-----|------|------|-----|------|-----|-----|-----|-------|
| In-House | 0 | 0 | 0 | 16 | 20 | 53 | 0 | 0 | | | | | 89 |
| Academy/Other | 358 | 200 | 190 | 0 | 20 | 0 | 16 | 7 | | | | | 791 |
| Instructor Hours | 0 | 0 | 0 | 2 | 0 | 0 | 0 | 0 | | | | | 2 |
| Total Training Hours | 358 | 200 | 0 | 16 | 40 | 53 | 16 | 7 | | | | | 690 |

ADMINISTRATIVE INVESTIGATIONS

| DESCRIPTION | Jan | Feb | Mar | April | May | June | July | Aug | Sept | Oct | Nov | Dec | Total |
|--------------------------|-----|-----|-----|-------|-----|------|------|-----|------|-----|-----|-----|-------|
| Allegations received | 0 | 0 | 0 | 0 | 0 | 0 | 0 | 0 | | | | | 0 |
| Unfounded | 0 | 0 | 0 | 0 | 0 | 0 | 0 | 0 | | | | | 0 |
| Founded | 0 | 0 | 0 | 0 | 0 | 0 | 0 | 0 | | | | | 0 |
| Not Sustained | 0 | 0 | 0 | 0 | 0 | 0 | 0 | 0 | | | | | 0 |
| Investigation in Process | 0 | 0 | 0 | 0 | 0 | 0 | 0 | 0 | | | | | 0 |
| Administrative Closure | 0 | 0 | 0 | 0 | 0 | 0 | 0 | 0 | | | | | 0 |
| Commendations | 0 | 0 | 0 | 0 | 0 | 0 | 0 | 0 | | | | | 0 |

ANIMAL CONTORL

| DESCRIPTION | Jan | Feb | Mar | April | May | June | July | Aug | Sept | Oct | Nov | Dec | Total |
|-------------------------|-----|-----|-----|-------|-----|------|------|-----|------|-----|-----|-----|-------|
| Calls for Service | 34 | 73 | 64 | 76 | 87 | 92 | 86 | 96 | | | | | 608 |
| Animal Bite Rpts. | 2 | 3 | 2 | 2 | 1 | 3 | 3 | 1 | | | | | 17 |
| At Large Complaints | 11 | 36 | 25 | 33 | 26 | 23 | 34 | 53 | | | | | 241 |
| Barking Dog Complaints | 2 | 0 | 2 | 3 | 2 | 1 | 0 | 4 | | | | | 14 |
| Skunk Complaints | 2 | 5 | 4 | 7 | 6 | 12 | 7 | 3 | | | | | 46 |
| Other Animal Complaints | 7 | 23 | 10 | 23 | 18 | 21 | 21 | 12 | | | | | 135 |
| Tickets issued | 1 | 2 | 1 | 3 | 3 | 2 | 2 | 0 | | | | | 14 |
| Verbal/Written Warning | 2 | 9 | 9 | 11 | 9 | 11 | 17 | 14 | | | | | 82 |
| Animals Returned | 5 | 16 | 15 | 18 | 9 | 22 | 30 | 28 | | | | | 143 |
| Dead Animals Removed | 6 | 12 | 7 | 6 | 5 | 12 | 10 | 6 | | | | | 64 |
| Traps Set | 8 | 12 | 68 | 82 | 76 | 116 | 76 | 68 | | | | | 506 |
| Animals Trapped | 0 | 2 | 5 | 6 | 6 | 8 | 9 | 5 | | | | | 41 |
| Lost Animals | 3 | 7 | 5 | 2 | 6 | 11 | 14 | 9 | | | | | 57 |
| Injured Animals | 1 | 4 | 1 | 2 | 1 | 3 | 2 | 6 | | | | | 20 |
| Impounded Animals | 8 | 8 | 8 | 6 | 5 | 4 | 4 | 9 | | | | | 52 |
| Rabies | 0 | 0 | 0 | 0 | 1 | 3 | 0 | 1 | | | | | 5 |



| Fire Department | Jan | Feb | March | April | May | June | July | Aug | Sep | Oct | Nov | Dec | Total |
|---------------------------|-----|-----|-------|-------|------|------|------|-------|-----|-----|-----|-----|-------|
| Inspections | 5 | 1 | 2 | 0 | 0 | 13 | 0 | 1 | | | | | 22 |
| Incidents | 18 | 11 | 11 | 16 | 16 | 20 | 22 | 14 | | | | | 128 |
| Fire Hydrants | 0 | 0 | 0 | 75 | 28 | 36 | 0 | 22 | | | | | 161 |
| Training Hours | 9 | 8 | 10 | 2 | 14.5 | 13 | 12.5 | 23.75 | | | | | 92.75 |
| Smoke Detector Install | 5 | 3 | 2 | 0 | 1 | 0 | 0 | 0 | | | | | 11 |
| Fire Extinguisher Install | 0 | 0 | 0 | 0 | 0 | 0 | 0 | 0 | | | | | 0 |
| Presentations | 0 | 1 | 0 | 0 | 0 | 0 | 0 | 0 | | | | | 1 |

Call Summary

Russell County Communications

133 W 8th St

Russell, KS 67665

County: Russell

Year:

2020

Agency Affiliation

Police

Report Date: 09/04/2020 06:36:01

Report Date From: 08/01/2020

Report Date To: 08/31/2020

Period Group: Month

Days Of Week: All

Call Type: All

Abandoned Filters: Include Abandoned

NSI Filters: NSI Included in 911 Totals

Agency Affiliation: All

| | August 2020 | Total |
|-------------------|-------------|--------|
| Inbound | 352 | 352 |
| Abandoned | 42 | 42 |
| Abandoned % | 10.66% | 10.66% |
| Unparsed | 0 | 0 |
| Total | 394 | 394 |
| Inbound | 0 | 0 |
| Abandoned | 0 | 0 |
| Outbound | 0 | 0 |
| Unparsed | 0 | 0 |
| Total | 0 | 0 |
| Inbound | 1,905 | 1,905 |
| Abandoned | 49 | 49 |
| Outbound | 504 | 504 |
| Unparsed | 0 | 0 |
| Total | 2,458 | 2,458 |
| Avg Call Duration | 89.2 | 89.2 |
| Total | 2,852 | 2,852 |

CITY OF



Permit Report

8/1/2020 - 8/31/2020

| Permit # | Permit Date | Project Address | Description | Project Cost | Primary Contractor |
|----------|-------------|-----------------|-------------|--------------|--------------------|
|----------|-------------|-----------------|-------------|--------------|--------------------|

Group: Building

| | | | | | |
|----------|-----------|-----------------|--------------------------|-----------|---------------------------------------|
| 20200270 | 8/31/2020 | 1278 N Seitz | Pre-construction Meeting | 0.00 | |
| 20200263 | 8/26/2020 | 321 S Kansas | Roofing | 4,000.00 | |
| 20200261 | 8/25/2020 | 331 N Brooks | Fence | 500.00 | |
| 20200260 | 8/25/2020 | 326 Hartman | Roofing | 11,000.00 | Stoppel Construction, LLC |
| 20200259 | 8/24/2020 | 303 N Culp St | 8' Carport | 2,400.00 | Coast to Coast Carports |
| 20200258 | 8/24/2020 | 1333 N Front St | Roofing | 5,000.00 | Pentad Properties Corp. |
| 20200257 | 8/24/2020 | 127 W 3rd St | Roofing | 5,000.00 | Pentad Properties Corp. |
| 20200256 | 8/24/2020 | 633 E 7th St | Roofing | 4,000.00 | Pentad Properties Corp. |
| 20200255 | 8/24/2020 | 30 N Grant St | Roofing | 7,000.00 | All Weather Roofing & Insulation |
| 20200250 | 8/17/2020 | 736 E. Sunset | 12 x 24 Shed | 7,500.00 | Sturdi-Bilt Storage Barns Inc |
| 20200249 | 8/17/2020 | 518 W 4th | Roofing | 12,000.00 | Mitchell Roofing |
| 20200248 | 8/14/2020 | 1404 N. Kansas | Roofing | 6,500.00 | |
| 20200247 | 8/13/2020 | 406 N Fossil | Fence | 1,000.00 | |
| 20200243 | 8/7/2020 | 636 W 3rd St | 30 x 40 Shed | 15,000.00 | Cleary Building Corp. |
| 20200241 | 8/6/2020 | 1232 N. Seitz | 26 x 30 Garage | 30,000.00 | Cook's Home Remodeling & Construction |
| | | | | | |

Group Total: 15

Group: Certificate of Occupancy

| | | | | | |
|----------|-----------|-------------|--------------------------|------|--|
| 20200268 | 8/28/2020 | 731 N. Main | Certificate Of Occupancy | 0.00 | |
| | | | | | |

Group Total: 1**Group: Electrical**

| | | | | | |
|----------|-----------|-----------------|----------------------------|----------|-------------------|
| 20200253 | 8/18/2020 | 558 E 3rd | Replace Electrical Service | 1,500.00 | Riedel Electric |
| 20200239 | 8/5/2020 | 308 N. Copeland | New Service | 1,300.00 | ESC Electric |
| 20200235 | 8/3/2020 | 128 E. 11th | New Service | 1,200.00 | Comfort Pro, Inc. |
| | | | | | |

Group Total: 3**Group: Electrical Safety Inspection**

| | | | | | |
|----------|-----------|-------------|------------------------------|------|--|
| 20200251 | 8/17/2020 | 1985 N Main | Electrical safety inspection | 0.00 | |
| | | | | | |

Group Total: 1**Group: Gas Inspection**

| | | | | | |
|----------|-----------|----------------|-------------------|------|---------------------------------|
| 20200244 | 8/10/2020 | 438 E. Wichita | Gas line air test | 0.00 | Don's Plumbing, Heating and Air |
| | | | | | |

Group Total: 1**Group: Mechanical**

| | | | | | |
|----------|-----------|------------------|---------------------|-----------|---------------------------------|
| 20200266 | 8/27/2020 | 627 W 2nd | Furnace Replacement | 9,000.00 | Don's Plumbing, Heating and Air |
| 20200265 | 8/27/2020 | 445 E. Wichita | Furnace Replacement | 7,800.00 | Russell Contractors |
| 20200264 | 8/27/2020 | 835 E. Wisconsin | Furnace Replacement | 7,000.00 | Russell Contractors |
| 20200254 | 8/19/2020 | 815 E. 7th St. | Furnace Replacement | 6,000.00 | Don's Plumbing, Heating and Air |
| 20200252 | 8/18/2020 | 815 N Main | Install HVAC System | 12,500.00 | Big A Contracting |
| | | | | | |

Group Total: 5**Group: Plumbing**

| | | | | | |
|----------|----------|------------------|--------------------------|--------|---------------------------------|
| 20200238 | 8/3/2020 | 650 E. Wisconsin | Water Heater Replacement | 900.00 | Don's Plumbing, Heating and Air |
| | | | | | |

Group Total: 1

Group: Property Line Locate

| | | | | | |
|----------|-----------|--------------------|----------------------|------|--|
| 20200269 | 8/31/2020 | 310 N Kansas | Property line locate | 0.00 | |
| 20200267 | 8/28/2020 | 1651 N Brooks | Property line locate | 0.00 | |
| 20200262 | 8/26/2020 | 1421 N. Kansas | Property line locate | 0.00 | |
| 20200246 | 8/10/2020 | 306 N Ober | Property line locate | 0.00 | |
| 20200245 | 8/10/2020 | 65 S. Elm | Property line locate | 0.00 | |
| 20200242 | 8/6/2020 | 1404 N. Kansas | Property line locate | 0.00 | |
| 20200240 | 8/6/2020 | 1415 N Krug | Property line locate | 0.00 | |
| 20200237 | 8/3/2020 | 736 E. Sunset Ave. | Property line locate | 0.00 | |
| 20200236 | 8/3/2020 | 800 E. 2nd | Property line locate | 0.00 | |
| 20200234 | 8/3/2020 | 226 W 8th | Locate property line | 0.00 | |
| | | | | | |

Group Total: 10

| | | | | | |
|--|--|--|--|--|--|
| | | | | | |
|--|--|--|--|--|--|

Total Records: 37

8/31/2020

CITY OF



Case Report

8/1/2020 - 8/31/2020

| Case # | Case Date | Case Address | Description | Assigned To |
|--------|-----------|--------------|-------------|-------------|
|--------|-----------|--------------|-------------|-------------|

Group: Bed bugs in rental

| | | | | |
|----------|-----------|--|--------------------|-------------|
| 20200254 | 8/31/2020 | | Bed bugs in rental | Roger Sells |
| | | | | |

Group Total: 1

Group: General Nuisance

| | | | | |
|----------|-----------|----------------|------------------|-------------|
| 20200251 | 8/26/2020 | 1116 N. Main | General Nuisance | Kim Grizzle |
| 20200250 | 8/25/2020 | 1425 N. Kansas | General Nuisance | Kim Grizzle |
| 20200239 | 8/12/2020 | 1603 N. Kansas | General Nuisance | Kim Grizzle |
| 20200238 | 8/12/2020 | 1337 N. Elm | General Nuisance | Kim Grizzle |
| | | | | |

Group Total: 4

Group: Living in Camper

| | | | | |
|----------|----------|---------------|------------------|-------------|
| 20200229 | 8/4/2020 | 215 N Lincoln | Living in Camper | Roger Sells |
| | | | | |

Group Total: 1

Group: Mold in rental

| | | | | |
|----------|-----------|--|----------------|-------------|
| 20200255 | 8/31/2020 | | Mold in rental | Roger Sells |
| | | | | |

Group Total: 1

Group: Overgrowth

| | | | | |
|----------|-----------|-----------------|------------|-------------|
| 20200253 | 8/28/2020 | 1541 N. Lincoln | Overgrowth | Kim Grizzle |
| 20200249 | 8/21/2020 | 86 S. Windsor | Overgrowth | Kim Grizzle |
| 20200248 | 8/20/2020 | 1445 N. Main | Overgrowth | Kim Grizzle |
| 20200247 | 8/20/2020 | 1435 N. Main | Overgrowth | Kim Grizzle |
| 20200246 | 8/18/2020 | 333 W 4th | Overgrowth | Kim Grizzle |
| 20200245 | 8/18/2020 | 1445 N. Main | Overgrowth | Kim Grizzle |
| 20200244 | 8/18/2020 | 303 N. Kansas | Overgrowth | Kim Grizzle |
| 20200243 | 8/18/2020 | 217 N. Kansas | Overgrowth | Kim Grizzle |
| 20200242 | 8/13/2020 | 345 W. 7th | Overgrowth | Kim Grizzle |
| 20200241 | 8/13/2020 | 321 S. Lincoln | Overgrowth | Kim Grizzle |
| 20200240 | 8/13/2020 | 209 S. Elm | Overgrowth | Kim Grizzle |
| 20200237 | 8/11/2020 | 974 E. 4th | Overgrowth | Kim Grizzle |
| 20200236 | 8/11/2020 | 57 S. Elm | Overgrowth | Kim Grizzle |
| 20200235 | 8/11/2020 | 51 S. Elm | Overgrowth | Kim Grizzle |
| 20200234 | 8/10/2020 | 209 E. 13th | Overgrowth | Kim Grizzle |
| 20200232 | 8/6/2020 | 983 W. Wichita | Overgrowth | Kim Grizzle |
| 20200231 | 8/5/2020 | 1541 N. Lincoln | Overgrowth | Kim Grizzle |
| 20200230 | 8/5/2020 | 950 E. 7th | Overgrowth | Kim Grizzle |
| 20200228 | 8/4/2020 | 528 E. 12th | Overgrowth | Kim Grizzle |
| | | | | |

Group Total: 19

Group: Unsafe service entrance

| | | | | |
|----------|-----------|---------------|-------------------------|-------------|
| 20200252 | 8/28/2020 | 1612 N. Maple | Unsafe service entrance | Roger Sells |
| | | | | |

Group Total: 1

| | | | | |
|--|--|--|--|--|
| | | | | |
|--|--|--|--|--|

Total Records: 27

8/31/2020

**Russell Public Library Board Meeting
Monday, July 20, 2020**

Call to order: Vice President Sandy Ochampaugh called the meeting to order. Other board members present were: Andrea Cross, Audrey Lofland, Mayor Curt Mader, Gay Busker, Amanda Smith, and Margaret Walter. Library Director, Jessica McGuire was in attendance. Dan Krug was absent.

Approval of minutes: Curt moved the minutes from the June 15, 2020 meeting be approved. The motion was seconded by Margaret and the motion passed with the following voting yes: Sandy Ochampaugh, Andrea Cross, Audrey Lofland, Mayor Mader, Gay Busker, Margaret Walter and Amanda Smith.

Communication: See agenda for full details. The library has been enrolled in auto-pay with The Hartford (Russell Public Library's Insurance Company). Additional unemployment insurance will need to be paid in the amount of \$1,250 as per a premium audit. A panic button from SimpliSafe was purchased for the circulation desk. High Plains Roofing is looking at completing the new roof in November. Jim Alexander and Barb Alexander resigned their positions on June 24, 2020. Alicia Freeman and Gabe McGuire were hired on June 24, 2020.

Bills: Curt moved the bills be paid as presented in the Description/Invoice spread sheet. This motion was seconded by Amanda. The motion passed with the following voting yes: Sandy Ochampaugh, Andrea Cross, Audrey Lofland, Mayor Mader, Gay Busker, Margaret Walter and Amanda Smith.

Treasurer's report: In House Income was \$68.00 and the City of Russell Payment was \$54,500.44.

Executive Session: Margaret moved that the board & Jessica McGuire withdraw into executive session for the period of 20 minutes to discuss a personnel issue; the motion was seconded by Andrea. The motion passed with the following voting yes: Sandy Ochampaugh, Andrea Cross, Audrey Lofland, Mayor Mader, Gay Busker, Margaret Walter and Amanda Smith.

Amanda moved that executive session be terminated prior to the 20 minute time limit. This was seconded by Audrey and the motion passed with the following voting yes: Sandy Ochampaugh, Andrea Cross, Audrey Lofland, Mayor Mader, Gay Busker, Margaret Walter and Amanda Smith.

Librarian's Report: Jessica shared circulation stats with the board. Many items have been weeded by library staff during June and July. Jessica has applied to the state library to receive CARES funds to help with Russell Public Library's COVID related expenses. A customer training service subscription has been purchased. Other items presented during the Librarians Report can be viewed in the agenda.

New Business: The board reviewed pages 1-16 and 23-24 of Russell Public Library Policies with several proposed changes. Andrea moved the library's policy document be accepted with the changes; the motion was seconded by Curt. The motion passed with the following voting yes: Sandy Ochampaugh, Andrea Cross, Audrey Lofland, Mayor Mader, Gay Busker, Margaret Walter and Amanda Smith. The board discussed payment for those providing story time. Jessica explained that preparation for story time was completed outside of scheduled library work hours and usually entails two presentation sessions (the session is repeated). Andrea moved that \$50 per week be paid to anyone providing story time. Curt seconded the motion and the motion passed with the following voting yes: Sandy Ochampaugh, Andrea Cross, Audrey Lofland, Mayor Mader, Gay Busker, Margaret Walter and Amanda Smith. Also under new business, Jessica explained the reasoning behind on-line payments for the Capital One credit card.

The board discussed requiring patrons to wear masks. Curt moved that beginning July 22, 2020 all patrons of Russell Public Library that are three years old or older will be required to wear a mask to access the library, per CDC guidelines. Andrea seconded the motion and the motion passed with the following voting yes: Sandy Ochampaugh, Andrea Cross, Audrey Lofland, Mayor Mader, Gay Busker, Margaret Walter and Amanda Smith.

The board discussed staffing and discussed having one library clerk on duty at some times. A decision was tabled until the August board meeting.

The board also discussed hours of operation but tabled any decision until the August board meeting.

Adjournment: Curt moved to adjourn the meeting with a second from Andrea. The motion passed with the following voting yes: Sandy Ochampaugh, Andrea Cross, Audrey Lofland, Mayor Mader, Gay Busker, Margaret Walter and Amanda Smith.

Gay Busker
Russell Public Library Board Secretary